

# Manual

## ScopeDome

## Arduino Card

PCB ver. 1.3.0, firmware ver. 4.9

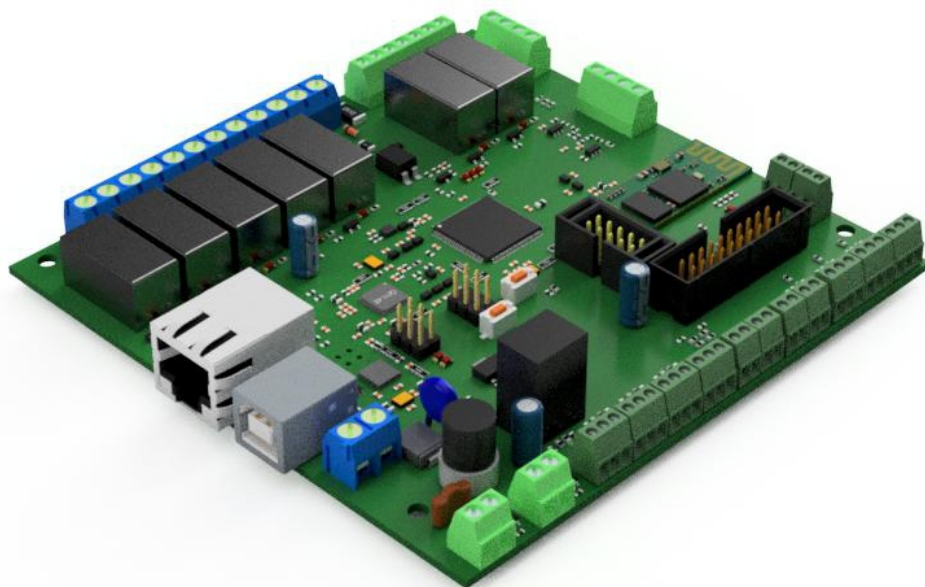

### Main features

Module designed to control the astronomical observatory  
Compatibility with the Arduino environment (Arduino Mega clone)  
Open Source communication protocol  
Control via Ethernet or USB  
Powered by an external power supply  
Two modules can be connected via BlueTooth in Master and Slave modes  
The Master module controls the dome's rotation, the Slave module controls the dome's shutter

### Specification

- driver compatible with Windows 7, 8, 10 (32 i 64 bit)
- module compatible with Arduino Mega (AtMega2560-16)
- built-in Ethernet module (W5200)
- built-in BlueTooth HC-05 module
- built-in pressure gauge
- built-in thermometer
- module power supply: external 12V / 2A power supply
- 2 x inputs for communication with a PC: Ethernet and USB
- 7 x electromechanical relays 230V / 5A
- 2 x Open Kolektor 12V / 2A power outputs with PWM control
- 4 x OneWire inputs
- 2 x SPI inputs
- touch screen connector
- 7 x logic inputs
- 2 x analog inputs
- 230V AC power detection input
- network configuration: static IP address or DHCP
- control method: USB cable or Ethernet network
- default IP address: 192.168.1.120 (port 80)
- working temperature range: -10 ° C to 30 ° C
- dimensions: 113 x 114 x 20 mm
- weight: 230 g

### Useful links

- SDK of the communication protocol with the card
- ScopeDome Driver ver. 5.5.5.11
- electrical diagrams of the card

# Observatory automation system components

ScopeDome Arduino Card PCB  
(master or slave)

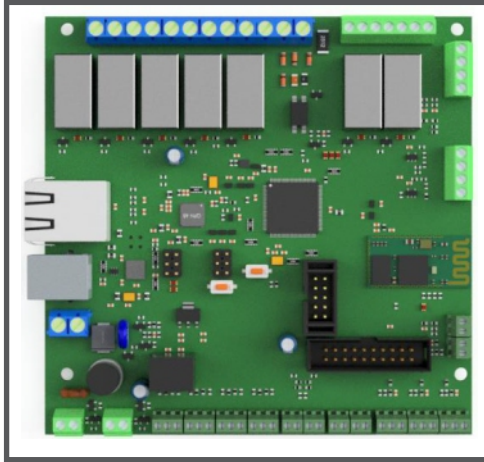

ScopeDome Arduino Keyboard PCB

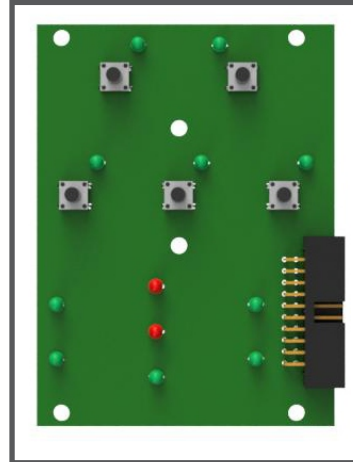

Emergency Keys PCB

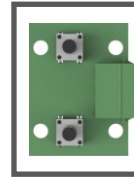

Power Contacts for 4M and 55M Dome

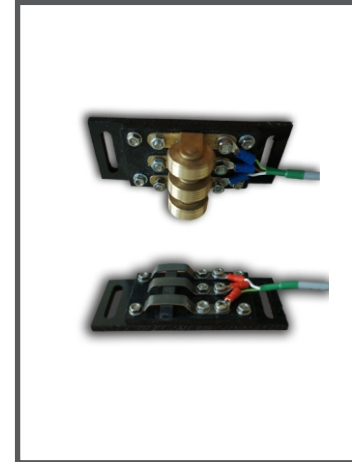

Limit Switches



Home Sensor in Box



Dome and Shutter Motor with Encoder



Dome Inverter



Shutter Inverter



ScopeDome Cloud and Rain Sensor



Higrometer



Thermometer

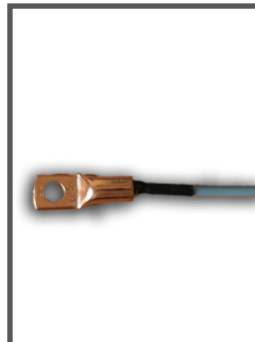

Motor Heater (12VDC or 230V AC)

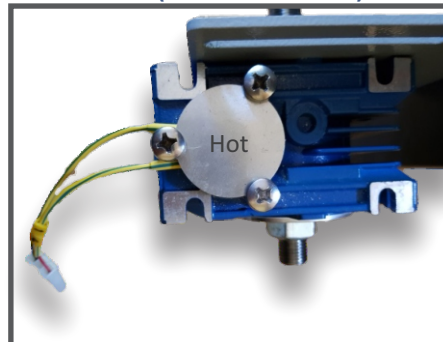

Box Heater (12V or 230V)

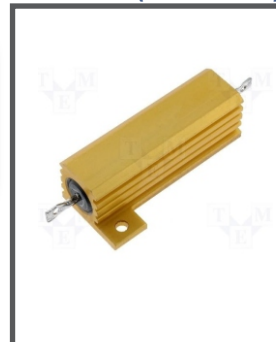

12VDC 1A Power Supply



\* if you plan to use mirror heaters it should be minimum 3A/12V DC

# Dome observatory control by ScopeDome Arduino Card

Block diagram

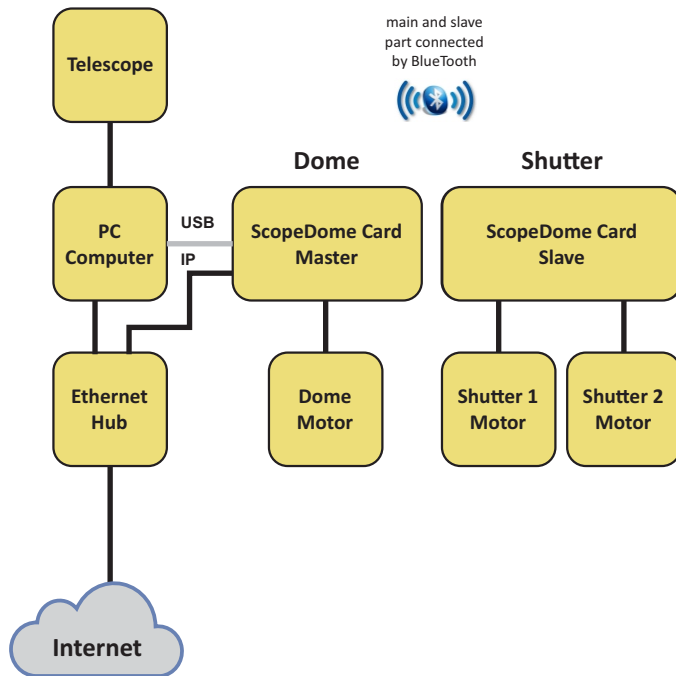

ScopeDome driver window

ScopeDome LS | ScopeDome Arduino Dome v10.13

Action Help

Main Shutters Sensors Buttons Relays Scripts Weather Internal Sensors Graph

Dome Commands and state info

003°54'43"  
GoTo: 015°00'00"

Dome commands

Open

CCW Stop CW

Close

GoTo 015

ENC. GoTo 0

Weather Prot. OFF

Sync with

Scope OFF

Sky OFF

Wind OFF

Relays Shutter

Relays Dome

Dome Action

Mode GoToAzPosition  
Dome Action GoToAzPosition 15°  
Rotation Rotate CW  
Shutter IsOpen

Telescope Command

Alt +035°33'03"  
Az +180°00'00"  
Ra +23h09m04s  
Dec +000°00'00"

Disc Home

Park

Map Point

Conn Side E-Part D

Driver

Config Exit

Dome State

180°

Dome Radar

Command Monitor

005. 02:32:07 | GoToAzPosition 15°  
004. 02:31:34 | Shutter Ascom Open  
003. 02:31:20 | Relay Fan On  
002. 02:31:19 | Relay CCD On  
001. 02:31:18 | Relay Telescope On  
000. 02:31:17 | Relay Light On

Enc: -40 | C: 042 | S: 267 | T: 33 |

# RollOffRoof observatory control by ScopeDome Arduino Card

Block diagram

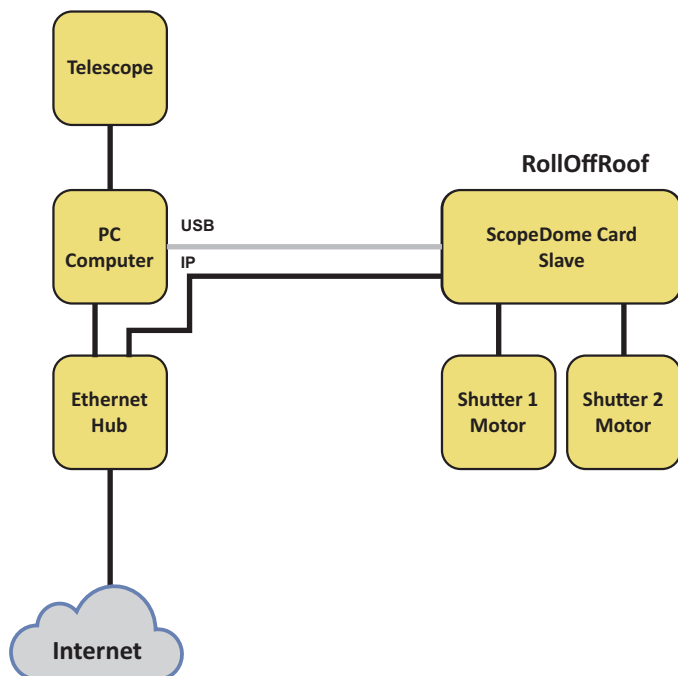

ScopeDome driver window

ScopeDome LS | ScopeDome Arduino RollOffRoof v10 f13

**Action Help**

Main Shutters Sensors Buttons Relays Scripts Weather Internal Sensors Graph

Shutters position ▲ ▼

**066 %**

RollOffRoof commands

Open

CCW Stop CW

Close

GoTo

ENC. GoTo

Weather Prot. OFF

Relays Shutter

Target Light Fan BOX MOTOR 1 2

Card action ◀

Mode **Shutters Close**

Dome Action **Shutter 1 Close**

Rotation **Stop**

Shutter **Closing Now**

Observatory info

66°

Obs. Radar

W N E S

Telescope Command

Alt +003°22'13"

Az +000°00'00"

Ra +22h40m25s

Dec +038°55'17"

AtPark Conn Side E-Part C

Command Monitor

006. 13:26:04 | Shutter Ascom Close

005. 13:25:21 | Shutter 1 Open To Long

004. 13:24:30 | Shutter Ascom Open

003. 13:22:49 | Shutter Ascom Close

002. 13:21:43 | Shutter Ascom Open

001. 13:21:40 | Relay Fan On

000. 13:21:39 | Relay Light On

Driver

Enc: 0 | C: 258 | S: 172 | T: 139 |



# Clamshell observatory control by ScopeDome Arduino Card

Block diagram

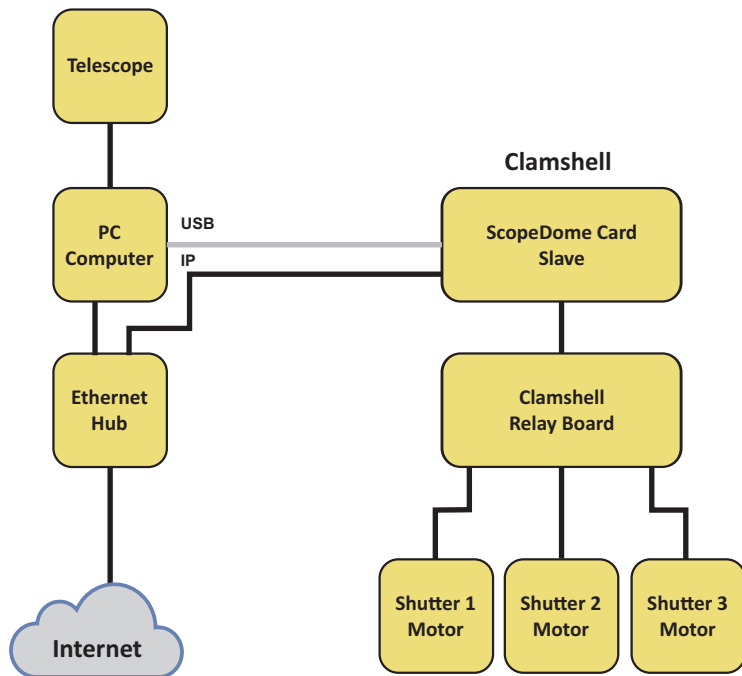

ScopeDome driver window

## 1. Info

The ScopeDome Arduino Card is a specialized PCB compatible with the Arduino platform. The card and software allow to control any type of observatory, not just ScopeDome production. Through the ASCOM platform it cooperates with popular telescopes. ScopeDome driver has built-in communication with the most popular cloud sensors and many weather stations. This allows the observatory to close automatically when weather conditions require it.

- a) Two ScopeDome Arduino Shield plates are required to control the dome. One programmed as Master, the other as Slave. The Master system controls the dome, the Slave system controls the dome's shutter. The systems connect via radio via the BlueTooth module.
- b) To control the RollOffRoof or Clamshell observatory, only one module programmed as Slave is required.
- c) The card can also be used as a simple relay controller controlled via the Internet or USB.

## 2. Basic functions of the card

- communication with a PC via the Internet (IP / Ethernet) or via USB
- rotating the dome in CW or CCW direction for a given number of encoder pulses
- opening or closing the observatory flaps (it is possible to control up to three flaps)
- dome Home Sensor position search
- counting the encoder pulses connected to the dome rotation motor
- enabling or disabling one of the relays
- heating control for the telescope's engines, electronics and mirrors
- together with the ScopeDome Cloud Sensor detection of clouds and rain

## 3. Additional security

- the card automatically deactivates the dome control engines when:
  - a) no pulses counting the position of the dome appear on the encoder for a set time
  - b) the dome position counter exceeds the programmed maximum value
- the card automatically turns off the shutter or roof control motors when the set time limit expires
- the card protects the engines by not allowing too fast switching the direction of movement of the dome or shutter
- built-in Limit Switch connectors interrupt the motor control signal in hardware
- Open / Close sensors stop the engine when the shutter close or open signal appears
- Telescope AtHome sensor allows blocking the opening of the shutter or sliding roof when the telesckop is not parked
- the card detects a 230V power outage allowing the dome to be closed when powered by UPS
- the card automatically resets when it is suspended (so-called WatchDog)
- after detecting clouds or rain it is possible to close the dome automatically
- UPS battery voltage measurement and the shutter closing when the voltage is too low

## 4. Description of connectors on the card

1. Ethernet (IP) input - card control
2. USB input - programming or card control
3. 12V DC card power input
  - power supply minimum 2A / 30W,
  - plus the power necessary to heat mirrors from PWM outputs
4. PWM2 - heating of the telescope mirror (max 2A)
5. PWM1 - heating of the telescope mirror (max 2A) or cloud sensor
6. Ow1 - engine thermometer
7. Ow2 - thermometer for measuring the outside temperature (Out)
8. Ow3 - mirror thermometer 1
9. Ow4 - mirror thermometer 2
10. Higrrometer - temperature and humidity in the dome
11. Pyrometer - input for connecting the ScopeDome Cloud sensor
12. Encoder - dome position measurement
13. Dome At Home Sensor - input indicating zero for the encoder
14. Telescope At Home Sensor - telescope parking sensor input
15. Cloud Sensor - input of an external cloud sensor - eg AAG
16. Rain Sensor - rain sensor input, eg AAG or ScopeDome
17. Voltage 64V - input for measuring beteria voltage from UPS
18. Pt100 - additional resistance temperature sensor
19. Close Sensor - input of the damper closing sensor
20. Close Limit Switch - the limit switch input for closing the damper
21. Open Sensor - shutter opening sensor input
22. Open Limit Switch - limit switch opening for flap opening
23. Dome or shutter direction control relay (CW/Com/CCW) or Open/Com/Close)
24. Heating control relay (Motor / Com / Electronics)
25. 230V AC supply sensor
26. Relay controlling camera power supply
27. Telescope power supply relay
28. Router power control relay (WatchDog)

Button and Led Connector - dedicated cards can be connected to this PCB with necessary buttons and LEDs to allow control the relays.

Display Connector - the card has a built-in connector for touch LCD display connection working on the SPI bus.

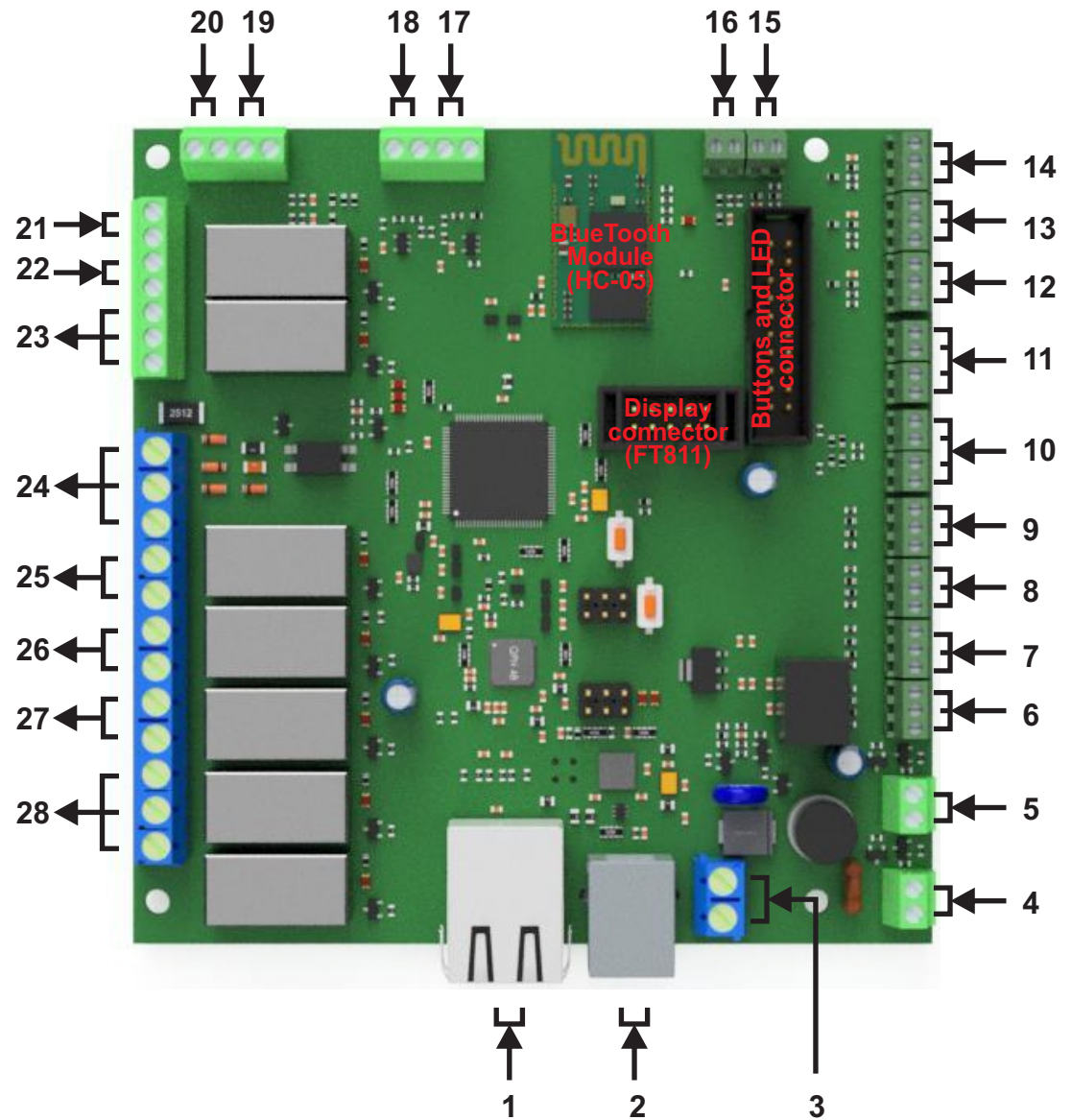

## 6. Software installation

**Note:** Connect the card to your computer only after installing the software below.

The software must be installed in the order listed:

- a) (Optional) ArduinoIDE: <https://www.arduino.cc/en/Guide/windows>
- b) ASCOM platform: <https://ascom-standards.org>
- c) ScopeDome Driver: <http://www.scopedome.com/en/download-program.aspx>

After installing all software modules, you can connect the card to a PC via a USB port.

At this time, the card should be recognized by Windows and assigned to one of the free COM ports.

## 7. Card configuration

If you bought the card directly from ScopeDome you will receive it with programmed Master and Slave modules and paired BlueTooth modules.

The card will not require additional programming. The IP address will be set to 192.168.1.120.

If you want to program the card's advanced features - including the IP address, you must connect the card via USB during configuration.

## 8. Configuring the connection with PC in the ScopeDome Driver program

The Arduino card can work with a PC in two ways:

- a) via USB
- b) via the Internet

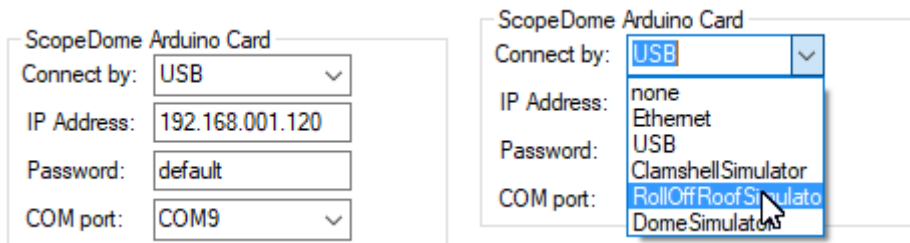

Select the appropriate option in "Connect By" in the Config-> Card-> ScopeDome Arduino Card window.

With this option you can also force the driver to work in simulator mode.

We recommend connecting via the Internet.

In our opinion it works much more stable when controlling dome motors. This type of control is more resistant to interference from three-phase motors arising during their start-up.



## 9. Searching the Arduino card in the local network in the ScopeDome Arduino Card - Test App

Press **Find Arduino IP** button and wait until the list of available devices appears in the **Chose Arduino device list**.

The screenshot shows the 'ScopeDome Arduino Card - Test App' window. The 'Card' tab is active, displaying various configuration fields and buttons. The 'Find Arduino IP' button is highlighted. The 'Card Preset' section includes options for 'As Master' and 'As Slave', with 'Ethernet Shield' checked. The 'Set Eth Watchdog' section shows 'Enabled' for the watchdog, with IP address '192.168.1.1', port '80', and relay 'Power\_Reset'. The 'Board' section shows 'Master' selected. The 'Command Monitor' section is empty. The 'Last Command' section shows 'getStatus' as the last command.

ScopeDome Arduino Card - Test App

Card | Status | Status Txt | Thermometers | Emergency Shutter Close

Find Arduino IP | Cancel | Responce: SD\_ROLLOFF | Card Preset

As Master |  Ethernet Shield |  Use DHCP |  Log to Console | Dome Stop Pause: 2000 ms

As Slave

Choose Arduino device

Name: scopedome

Ip address: 192.168.1.120

MAC: DA3949D4FC3C

COM Port: COM11

Communication by: USB

Save Settings

Set Eth Watchdog | Enabled | 192.168.1.1 | 80 | Power\_Reset

Board | Card State Reading | Card Status Reading Interval

Master | Get Status | Start | 10 ms | Connect | Disconnect

Command Monitor:

Command: getStatus | Param 1: | Param 2: | Param 3: | Param 4: | Param 5: | Param 6: | Param 7: | Run command | Last Command: last command

The search may take about 3 minutes. Then select the appropriate item from the **Chose Arduino** device list and press the **Save Settings** button.

The card's IP address is also displayed in the Com Arduino IDE port monitor after enabling the Log to Console option and resetting the card.

Note: the Log to Console option must be disabled during normal operation of the ScopeDome driver, it can be enabled only for testing.

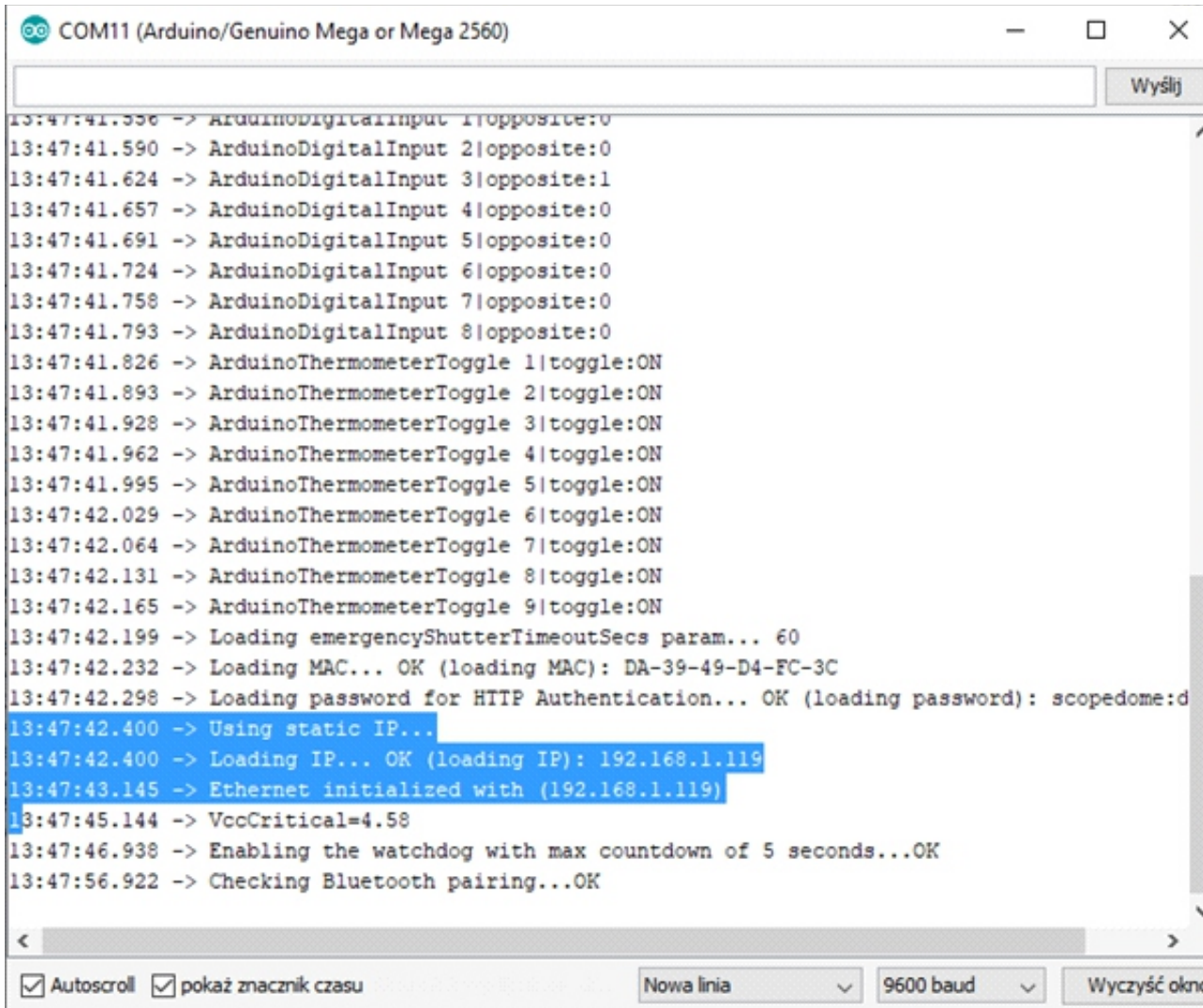

```
COM11 (Arduino/Genuino Mega or Mega 2560)
13:47:41.556 -> ArduinoDigitalInput 1|opposite:0
13:47:41.590 -> ArduinoDigitalInput 2|opposite:0
13:47:41.624 -> ArduinoDigitalInput 3|opposite:1
13:47:41.657 -> ArduinoDigitalInput 4|opposite:0
13:47:41.691 -> ArduinoDigitalInput 5|opposite:0
13:47:41.724 -> ArduinoDigitalInput 6|opposite:0
13:47:41.758 -> ArduinoDigitalInput 7|opposite:0
13:47:41.793 -> ArduinoDigitalInput 8|opposite:0
13:47:41.826 -> ArduinoThermometerToggle 1|toggle:ON
13:47:41.893 -> ArduinoThermometerToggle 2|toggle:ON
13:47:41.928 -> ArduinoThermometerToggle 3|toggle:ON
13:47:41.962 -> ArduinoThermometerToggle 4|toggle:ON
13:47:41.995 -> ArduinoThermometerToggle 5|toggle:ON
13:47:42.029 -> ArduinoThermometerToggle 6|toggle:ON
13:47:42.064 -> ArduinoThermometerToggle 7|toggle:ON
13:47:42.131 -> ArduinoThermometerToggle 8|toggle:ON
13:47:42.165 -> ArduinoThermometerToggle 9|toggle:ON
13:47:42.199 -> Loading emergencyShutterTimeoutSecs param... 60
13:47:42.232 -> Loading MAC... OK (loading MAC): DA-39-49-D4-FC-3C
13:47:42.298 -> Loading password for HTTP Authentication... OK (loading password): scopedome:d
13:47:42.400 -> Using static IP...
13:47:42.400 -> Loading IP... OK (loading IP): 192.168.1.119
13:47:43.145 -> Ethernet initialized with (192.168.1.119)
13:47:45.144 -> VccCritical=4.58
13:47:46.938 -> Enabling the watchdog with max countdown of 5 seconds...OK
13:47:56.922 -> Checking Bluetooth pairing...OK
```

**The sequence of commands in the Arduino Ide:**

- setLogging=1
- resetSoft
- setLogging=0
- IP change:
- setIp=192.168.1.119

## 10. Testing the card operation in the ScopeDome Arduino program - Test App

- select the communication method with the card (USB or Ethernet) and enter the appropriate IP address or COM port number
- press **Save Settings** button
- press **Connect** button
- press the **Get Status** button in the **Command Monitor** window. The card status should display, e.g.  
getStatus|OK|1:1:1:1:1:1;32000:32000;1:1:1:1:1:0;0:0:0:0#1:1:1:1:0;32000:32000;1:1:1:1:1:0;0:0:0:0 (...)
- in the Command drop-down list there is a list of all available orders supported by the card. You can run the selected command using **Run Command** button.
- in the **/Doc/ScopeDome\_Arduino\_Info\_4.9.pdf** file you will find a detailed description of the available orders.

## 11. Testing the card in a web browser

In the browser's address line, enter:

http://xxx.xxx.xxx.xxx/?switchOnRelay=1

http://xxx.xxx.xxx.xxx/?switchOffRelay=1

xxx.xxx.xxx.xxx - replace with your Arduino card's IP address

You will be asked to enter your username and password, enter:

user: scopedome

password: default

## 12. Programming the card operation mode in the ScopeDome Arduino program - Test App

Programowanie trybu działania karty oraz ustawień połączenia internetowego jest możliwe tylko poprzez port USB.

Przed zaprogramowaniem karty należy połączyć ją z komputerem poprzez łącze USB, a w oprogramowaniu sterującym wybrać odpowiedni numer portu COM.

Programming the card operation mode and Internet connection settings is only possible via the USB port.

Before programming the card, connect it to your computer via USB, and select the appropriate COM port number in the control software.

a) as Master - controlling the dome:

- run ScopeDome Arduino - Test App
- select the USB port to which the card is connected
- select the option Communication By: USB
- **select the option: Ethernet Shield**
- press Card Preset> As Master

b) as Slave - dome shutter control:

- run ScopeDome Arduino - Test App
- select the USB port to which the card is connected
- select the option Communication By: USB
- **deselect the option: Ethernet Shield**
- press Card Preset> As Slave

c) as Slave - controlling the RollOffRoof or Clamshell observatory

- run ScopeDome Arduino - Test App
- select the USB port to which the card is connected
- select the Communication By: USB option
- **select the option: Ethernet Shield**
- press Card Preset> As Slave

- d) pairing BlueTooth modules of Master and Slave cards
  - connect the power supply for both cards
  - program the cards - one as Master, the other as Slave
  - turn the power of both cards off and on
- wait about 30 seconds
- on both cards press the Pair button
- pairing will take about one minute
- if both BlueTooth modules communicate correctly, they will start to signal it by flashing synchronously on both cards with an LED in the Flash-Flash rhythm - Break (flash - 0.5s, break 1s)

## 14. Advanced programming of card operation mode

You can find more information on this topic in the file: **ScopeDome\_Arduino\_Info\_4.9.pdf** in sub-directory /DOC

## 15. Restore standard card settings

- a) Master
  - Set the parameters as in the picture below and press **As Master** button
- b) Slave
  - Set the parameters as in the picture below and press **As Slave** button

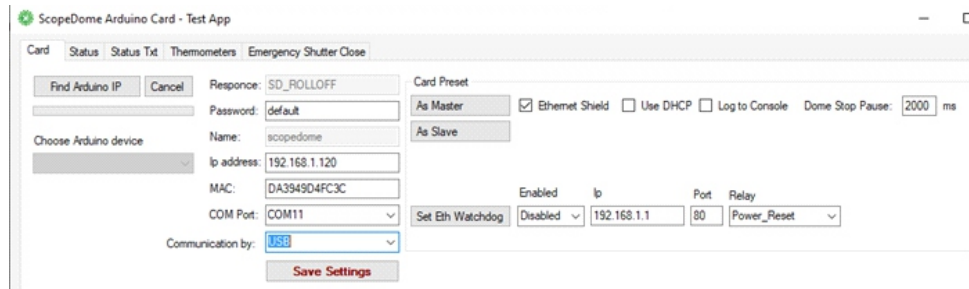

### Attention:

- the MAC and IP address of the card provided by you will also be programmed in this way.
- remember that Master and Slave cards will be assigned different Com port numbers - by programming them you should change the COM port settings
- after changing the COM port number, click Save Settings
- Preset As Master and Preset As Slave options work only when connected to the card via USB

# Card dimensions

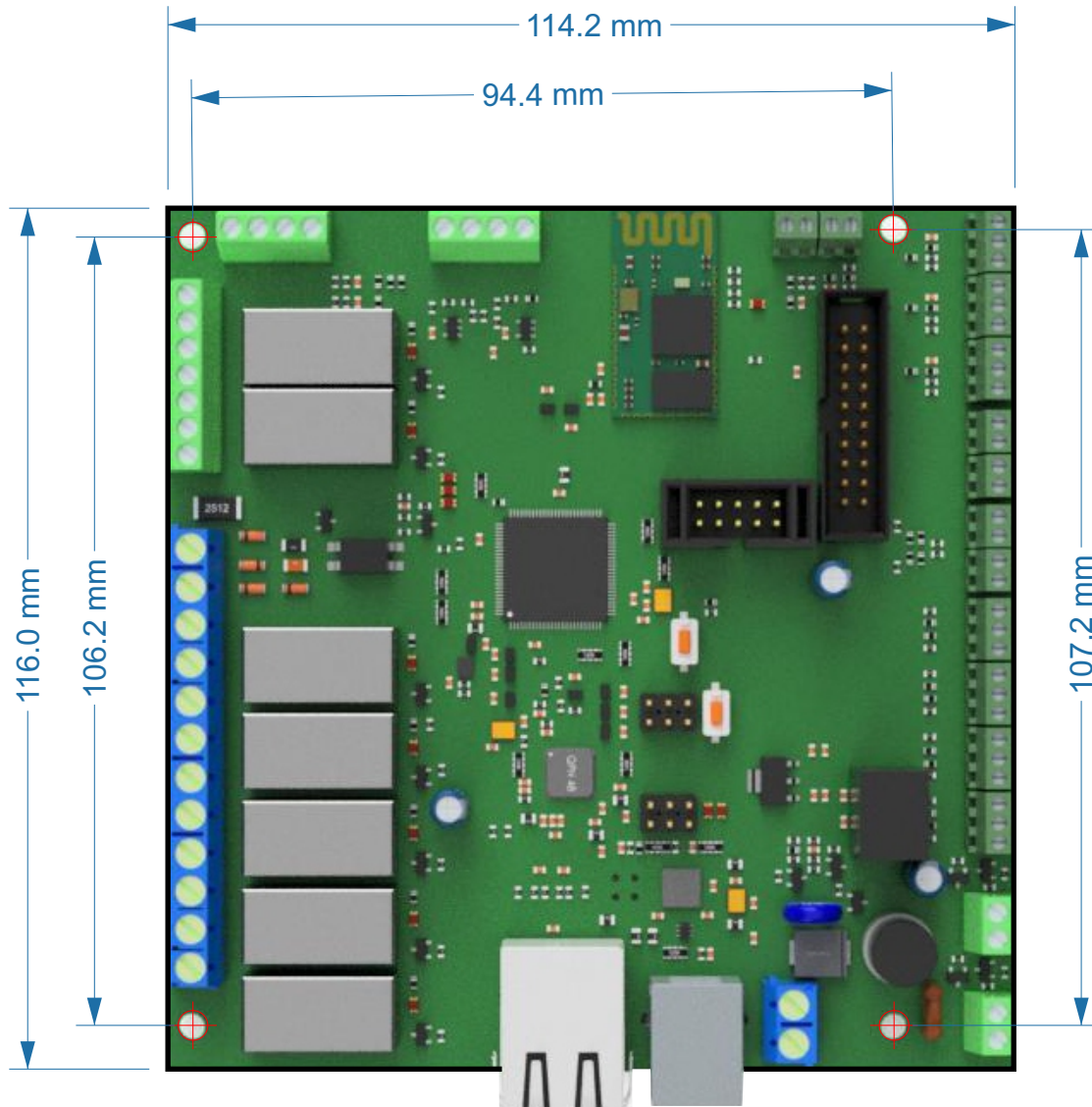

ScopeDome Arduino Card PCB (Master or Slave)

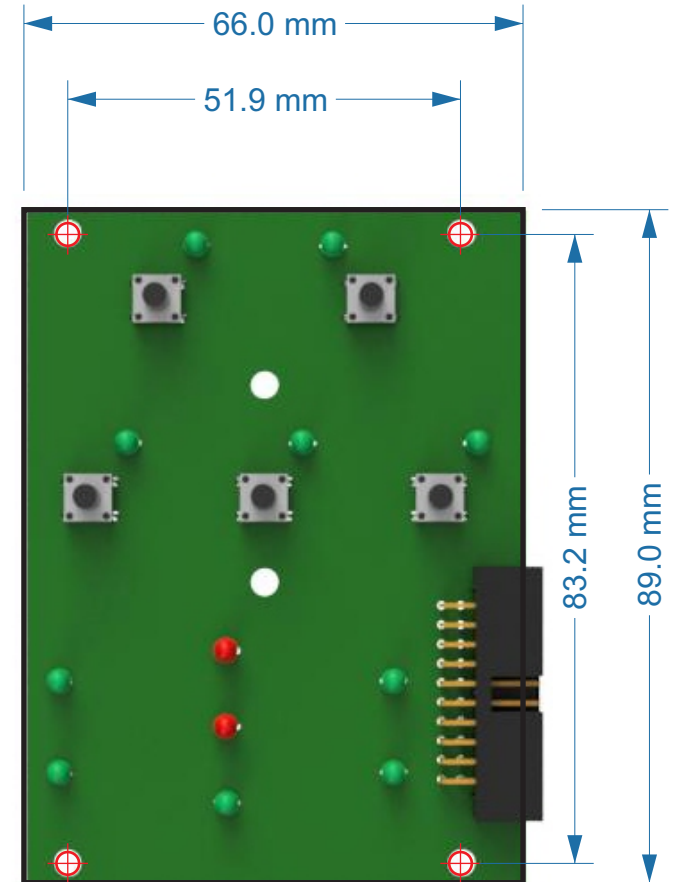

ScopeDome Arduino Keyboard PCB

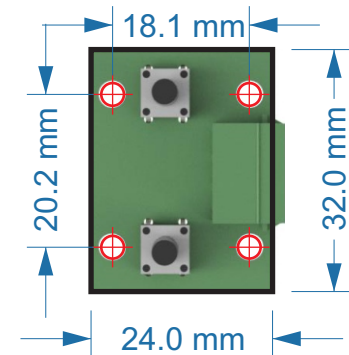

Emergency Keys PCB



# Diagram for 3M, 4M, 55M

## Dome part

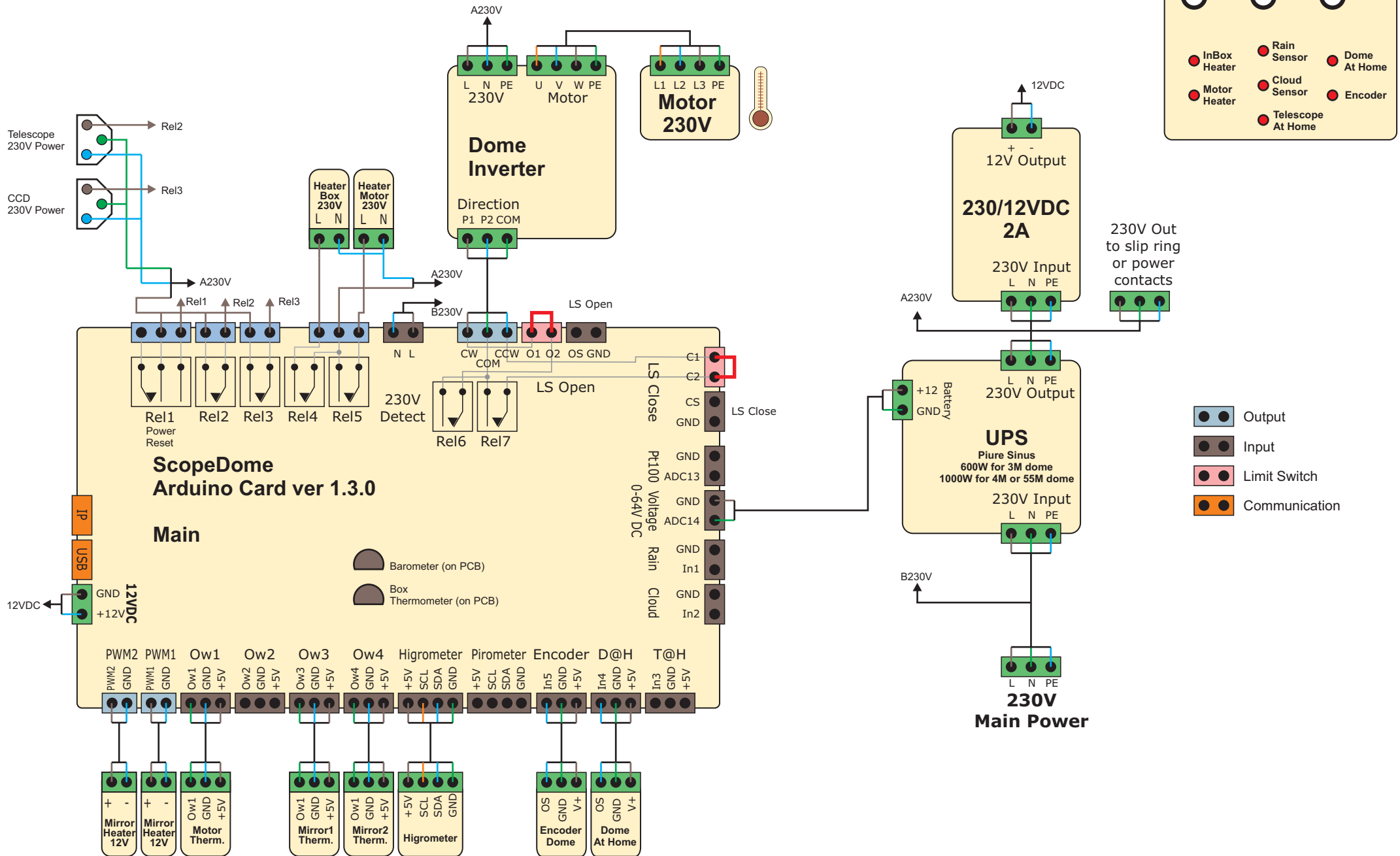

# Diagram for 3M, 4M, 55M

## Shutter part

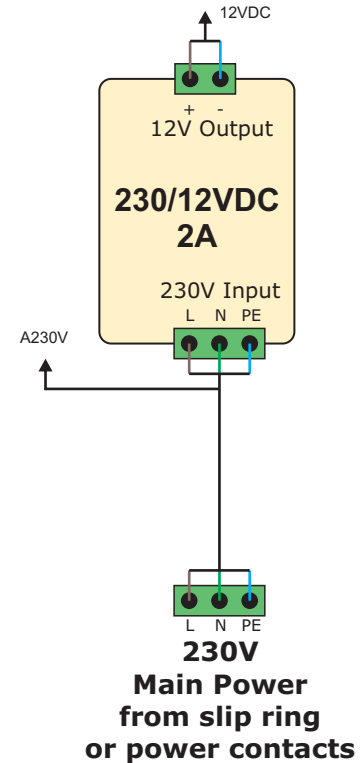
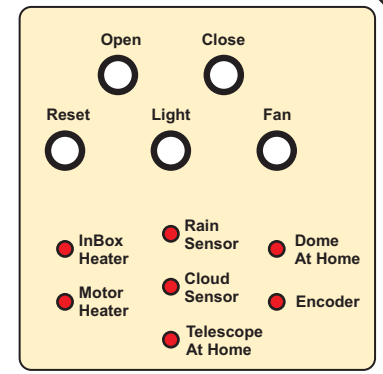
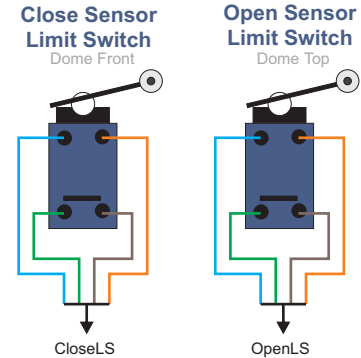
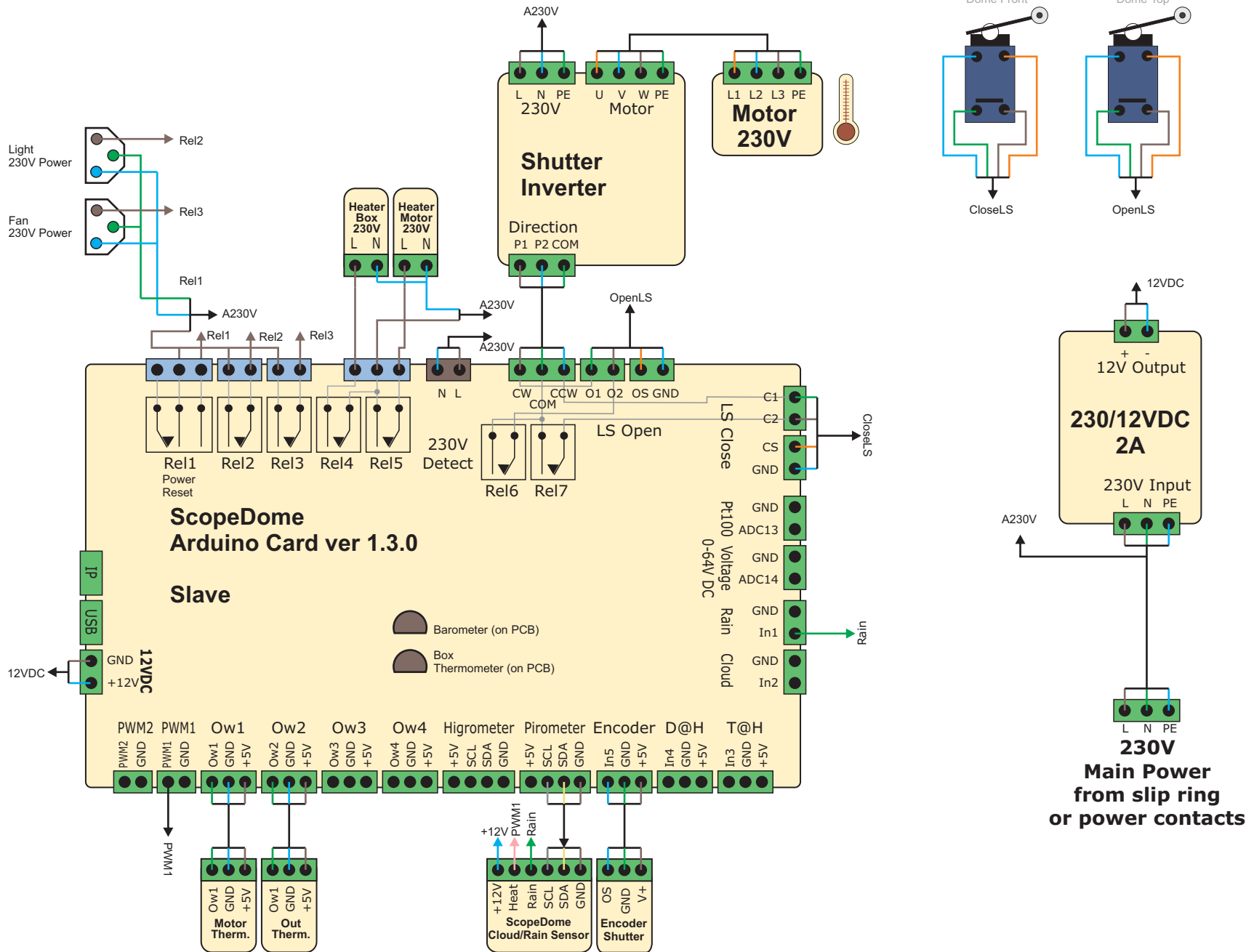

# Diagram for RollOffRoof observatory

## With One Shutter Control

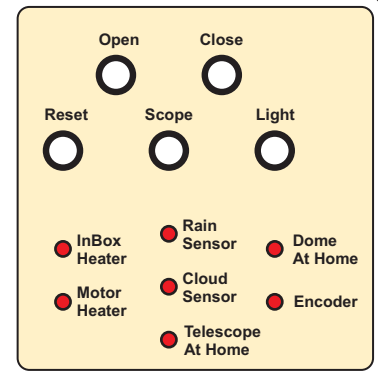
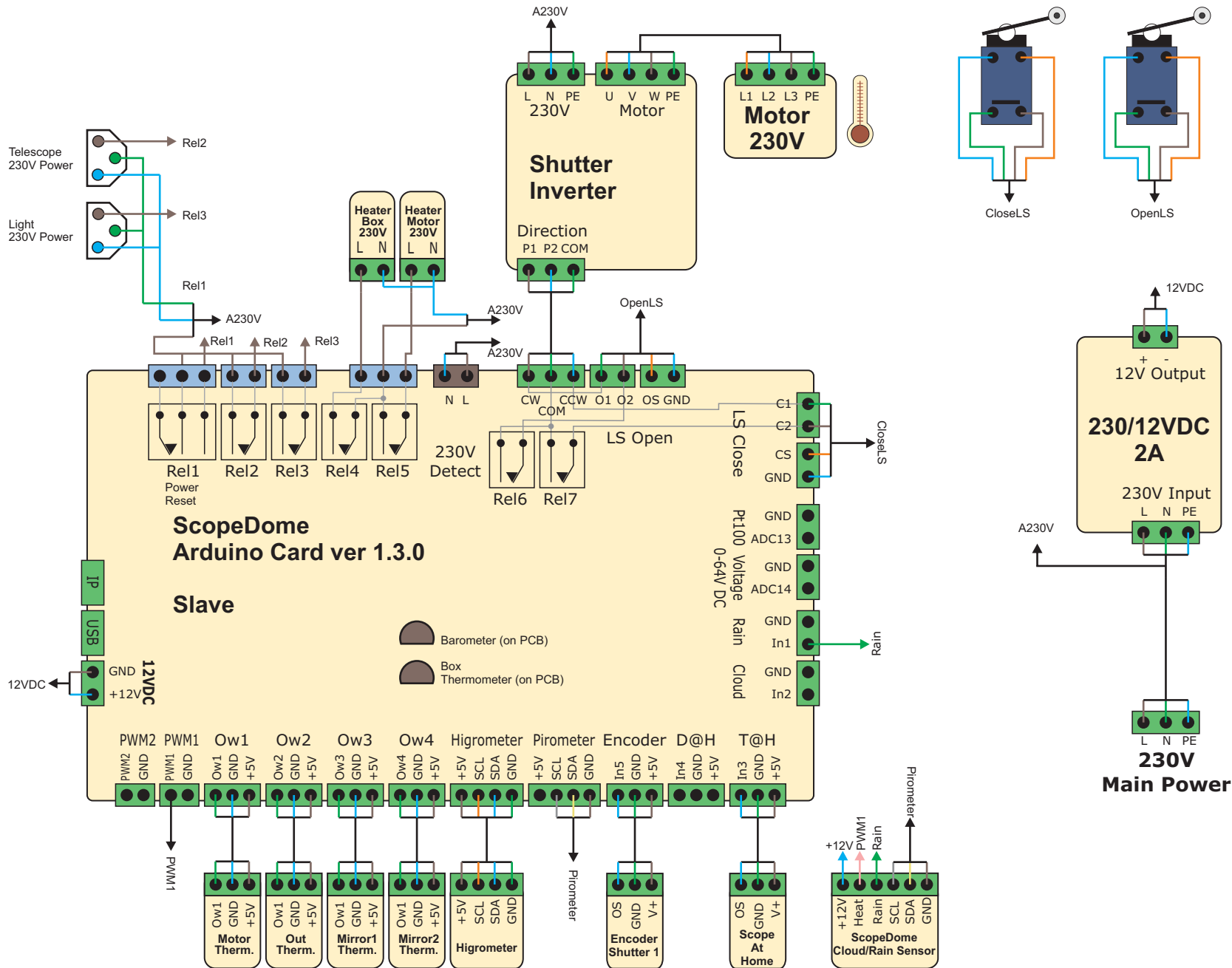

# Diagram for RollOffRoof observatory

## With Two Shutters Control

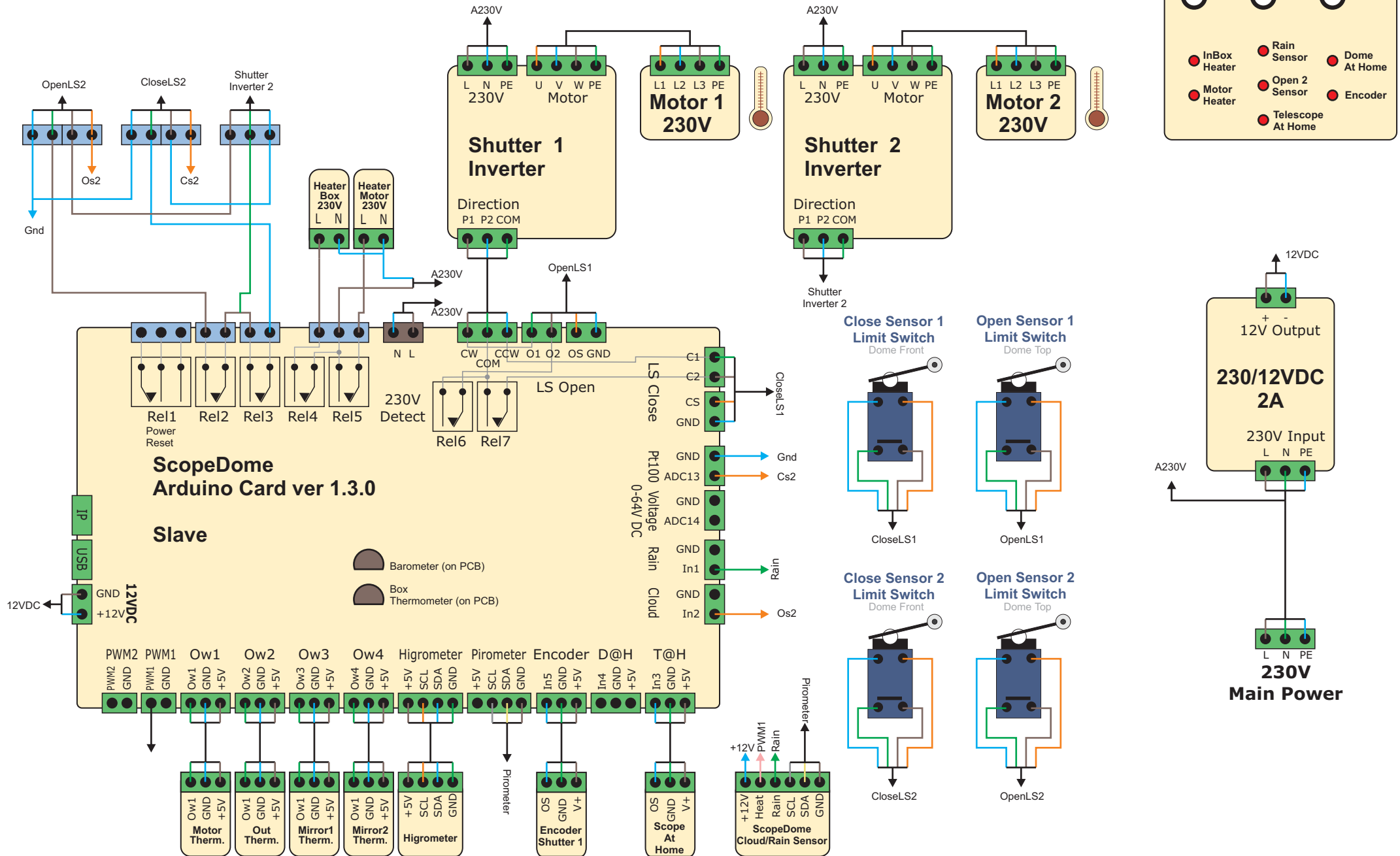

# Diagram for Clamshell 3M

## Clamshell dome

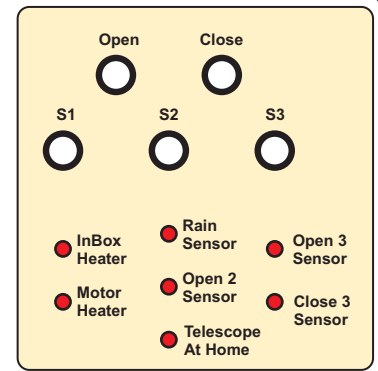
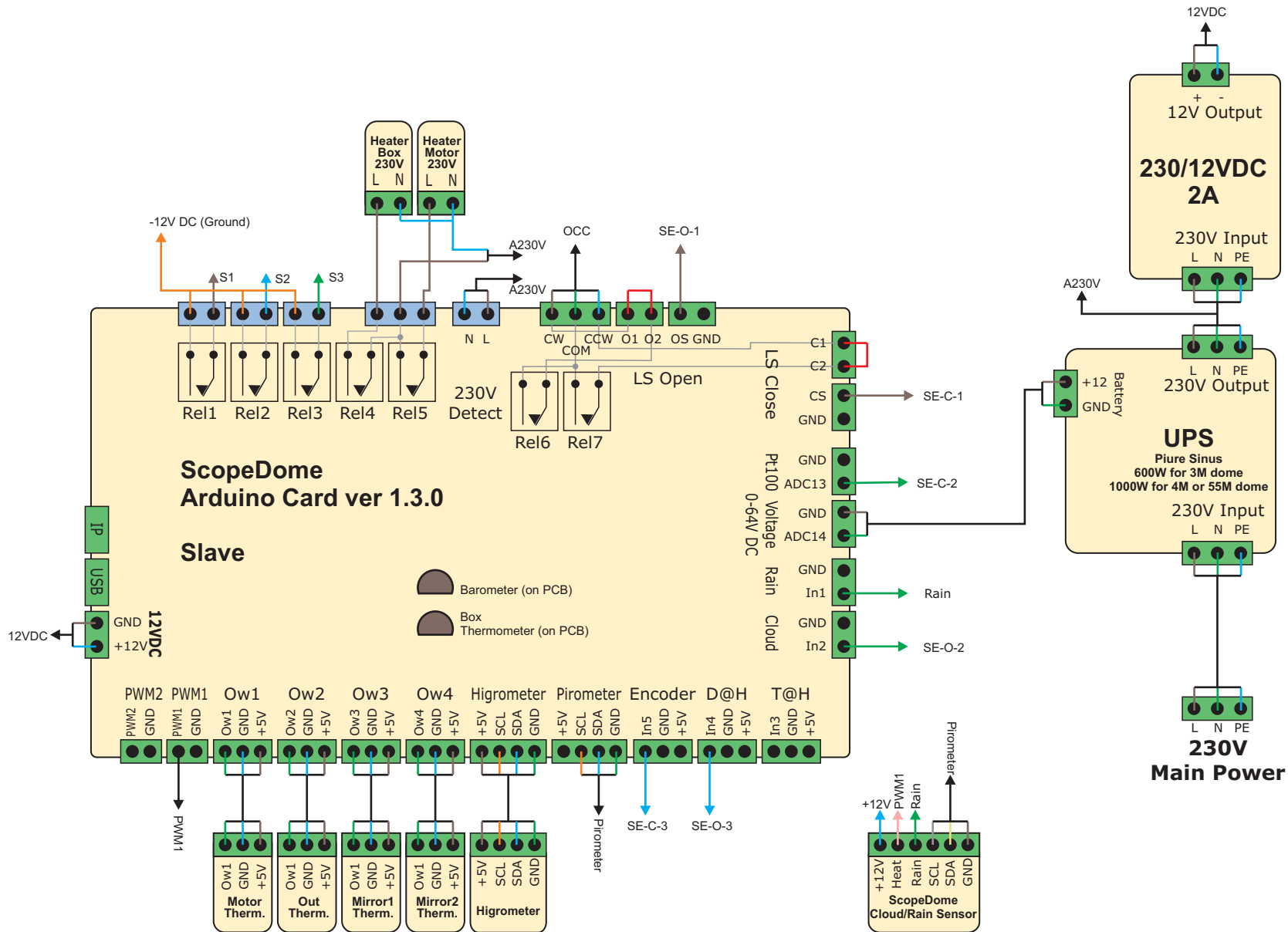



# Diagram for Clamshell 3M

## Clamshell Relay Board

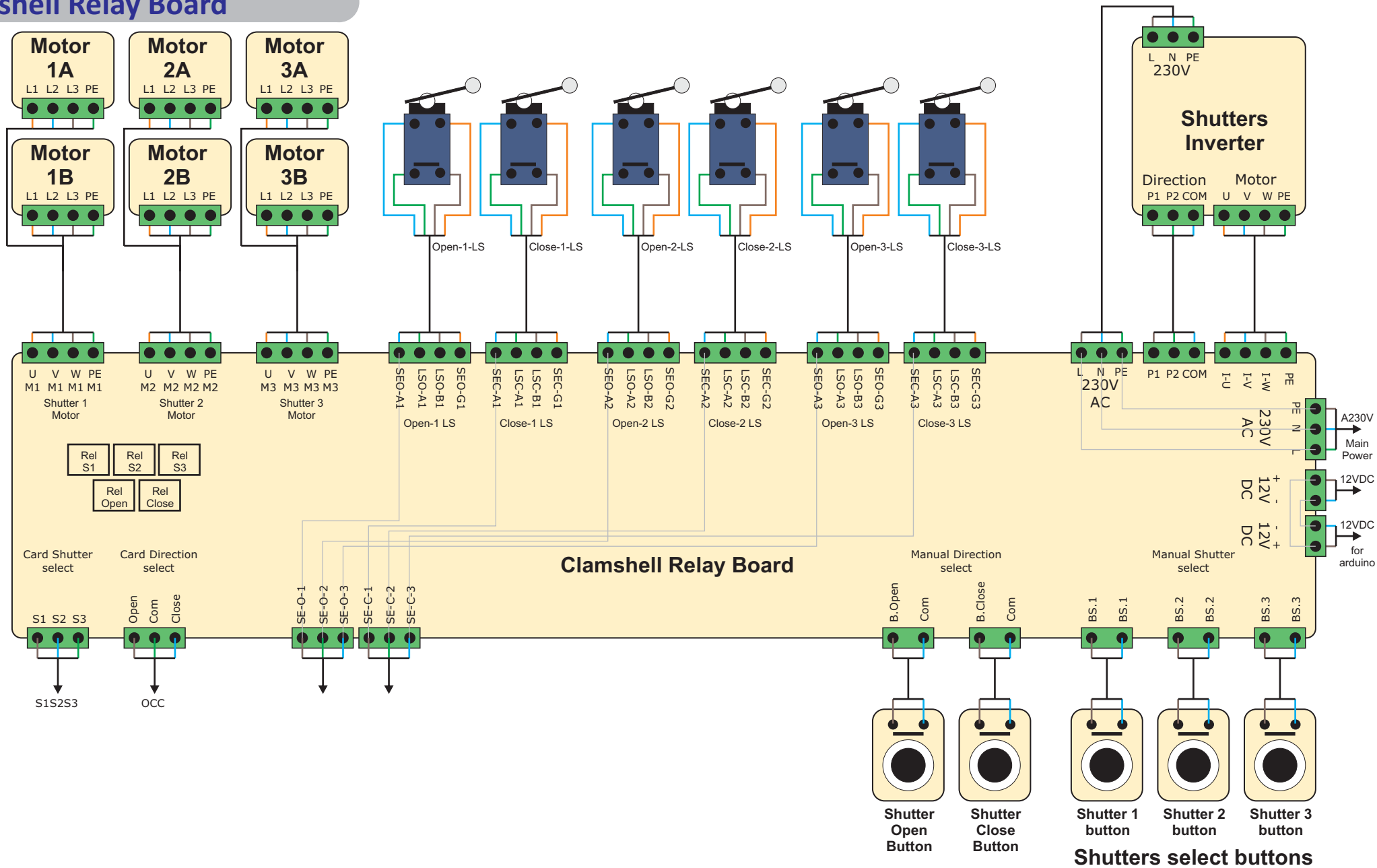

# Diagram for 2M

## Dome part

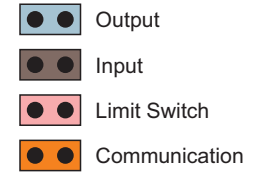
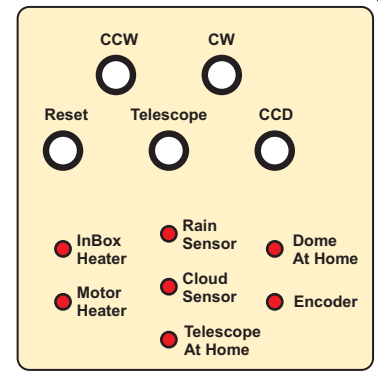
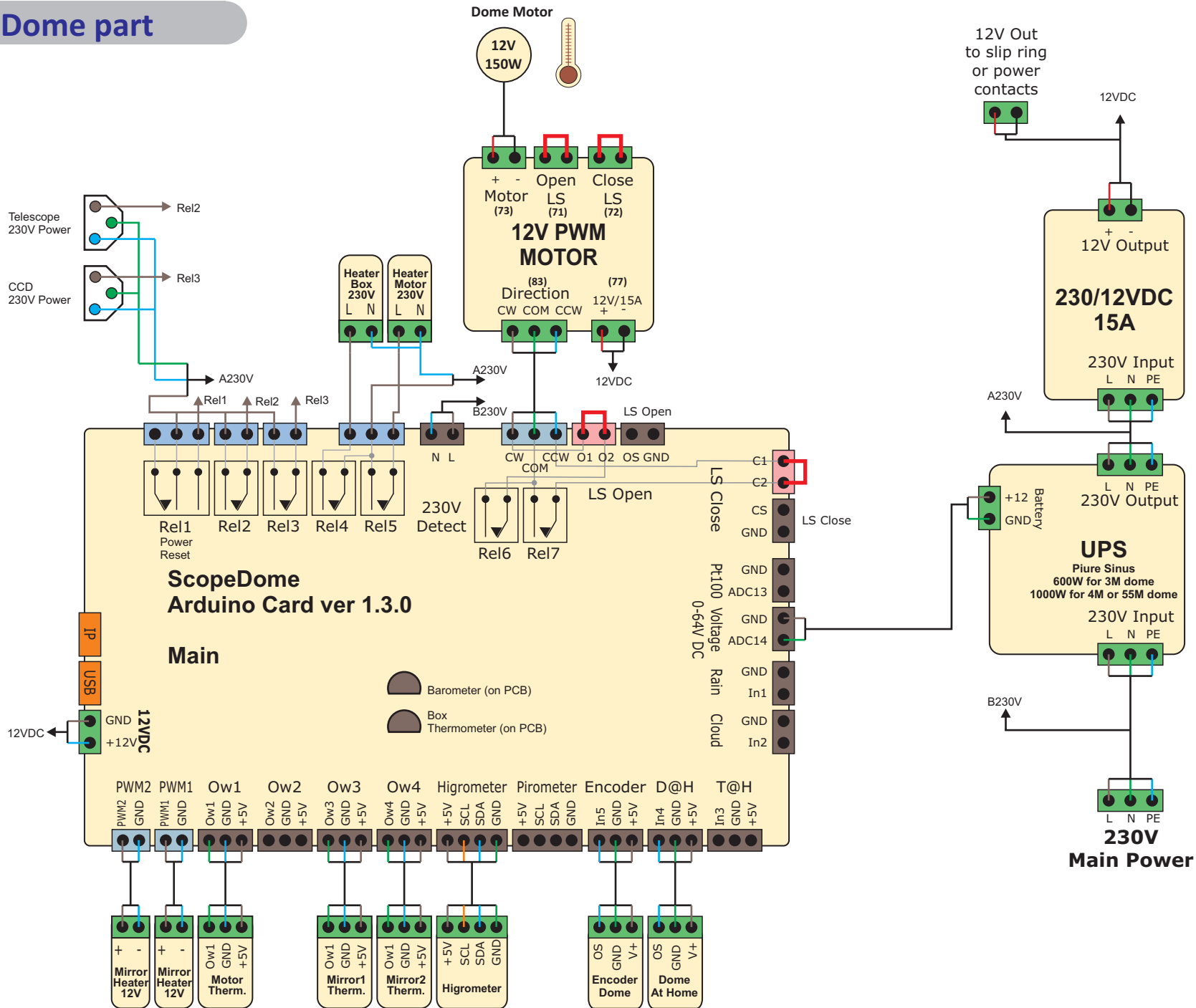

# Diagram for 2M

## Shutter part

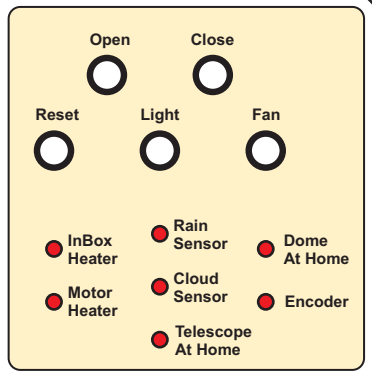
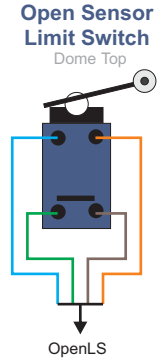
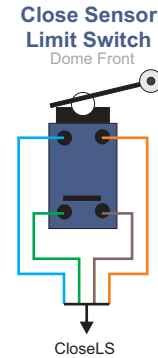
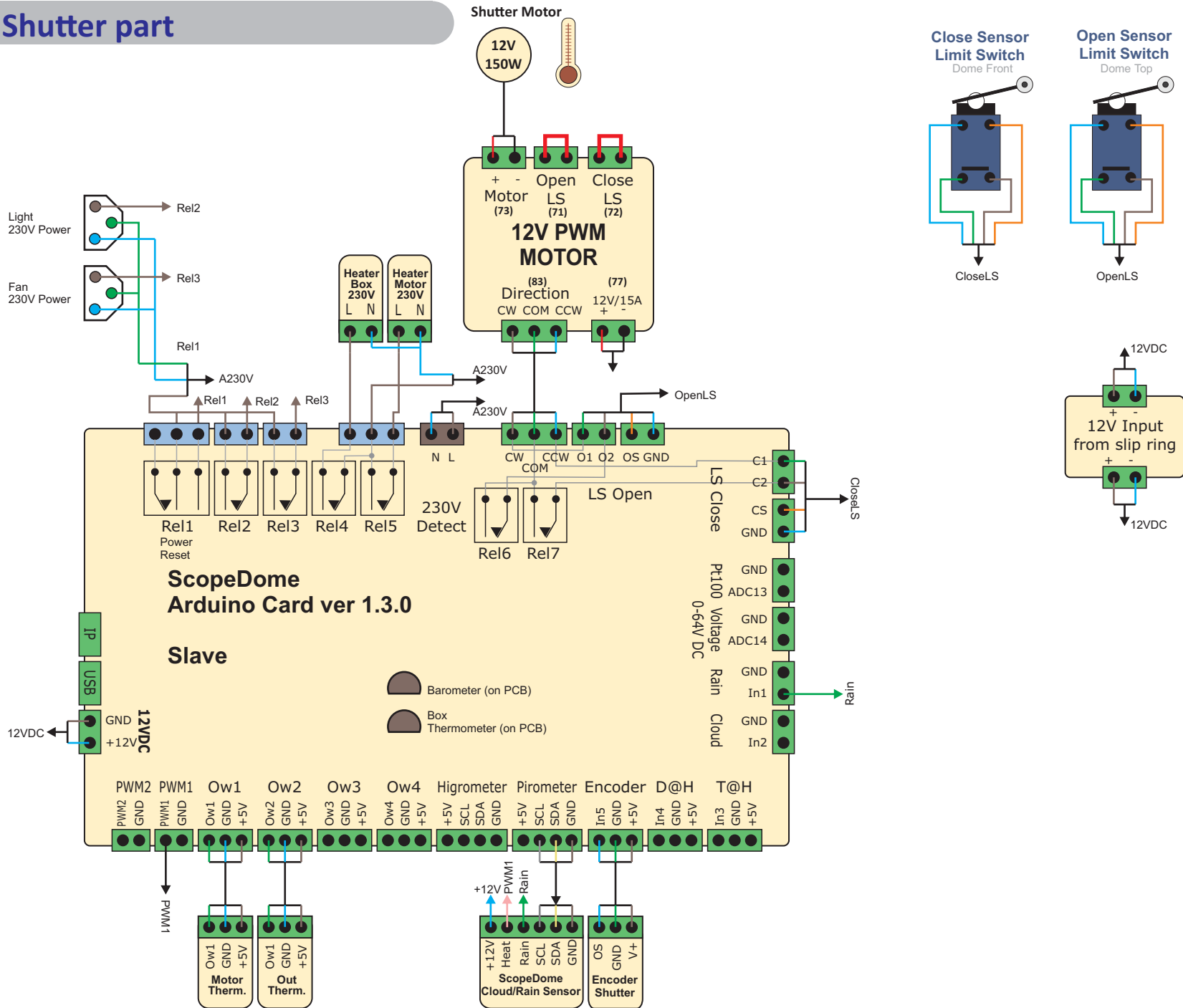

# ScopeDome Cloud and Rain Sensor

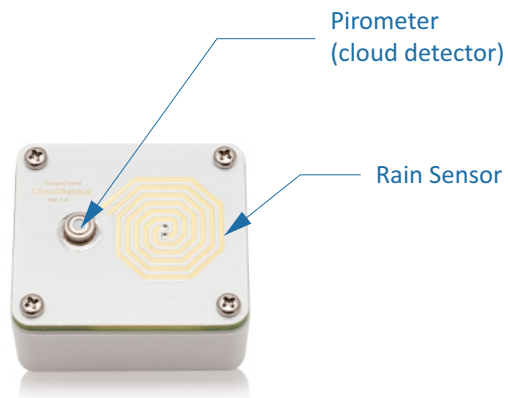

## Cloud Sensor Wires

- - White - Supply voltage +12 VDC for CloudSensor and RainSensor domains.
- - Green - RainSensor output (active state is LOW, not active is HI and internal pulled up).
- - Yellow - SDA of pyrometer (0 - 5 VDC logic states). (Arduino Mega Pin 20)
- - Gray - SCL of pyrometer (0 - 5 VDC logic states). (Arduino Mega Pin 21)
- - Brown - GND
- - Pink - Heater - high power input. Heating is on when applied high voltage here +12 VDC, around 14W power

## Cloud Sensor installation

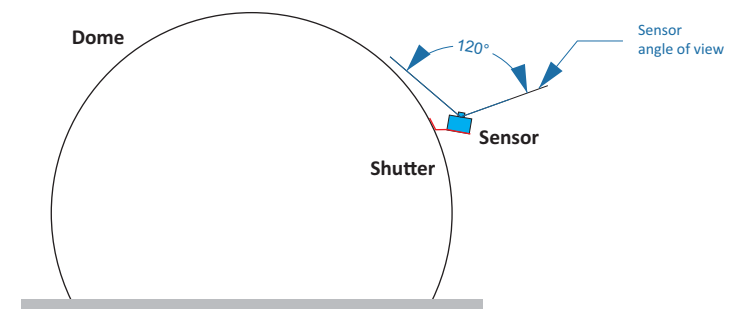



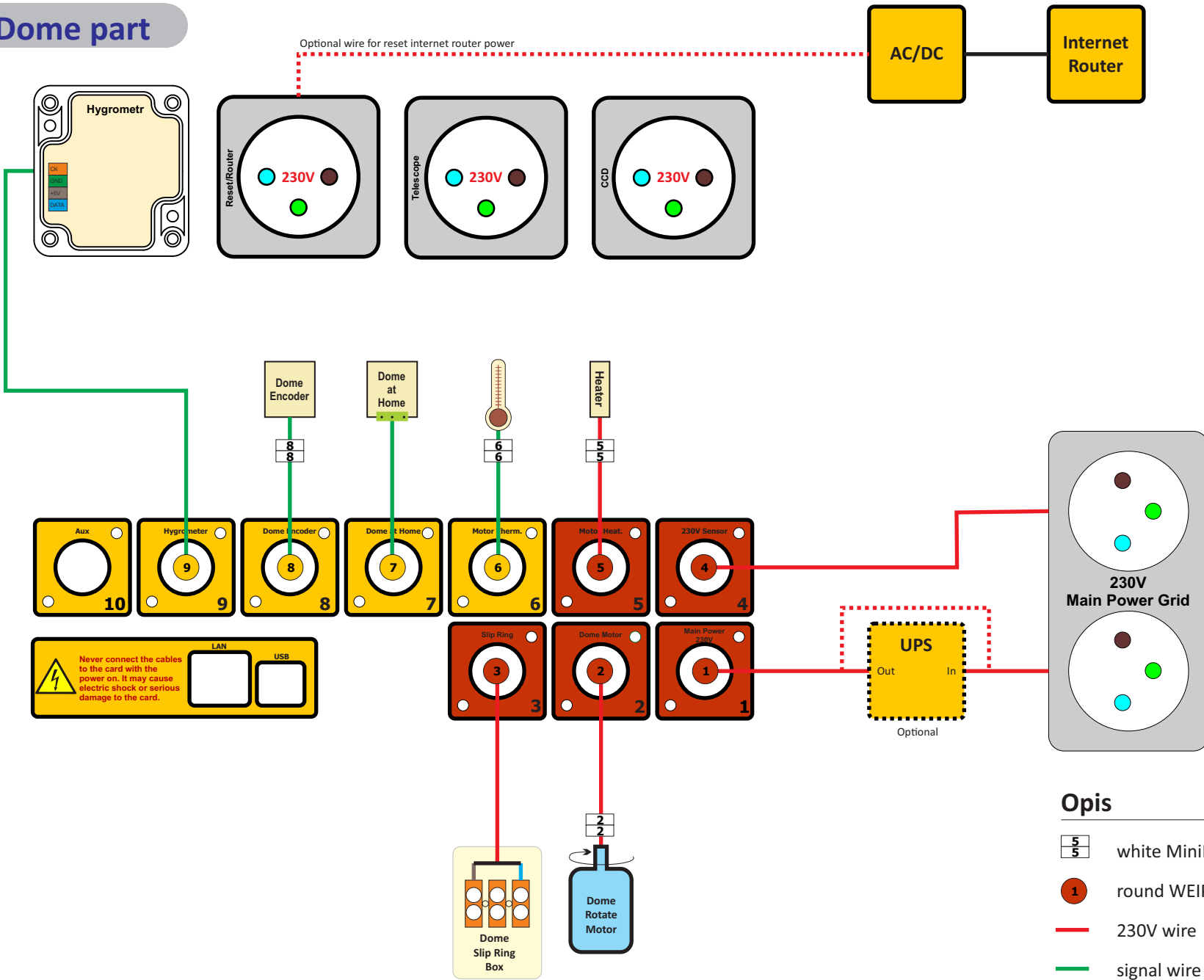

# 3M,4M,55M - PlugAndPlay wiring

## Dome part



### Opis

-  white MiniFit connector
-  round WEIP'u connector
-  230V wire
-  signal wire





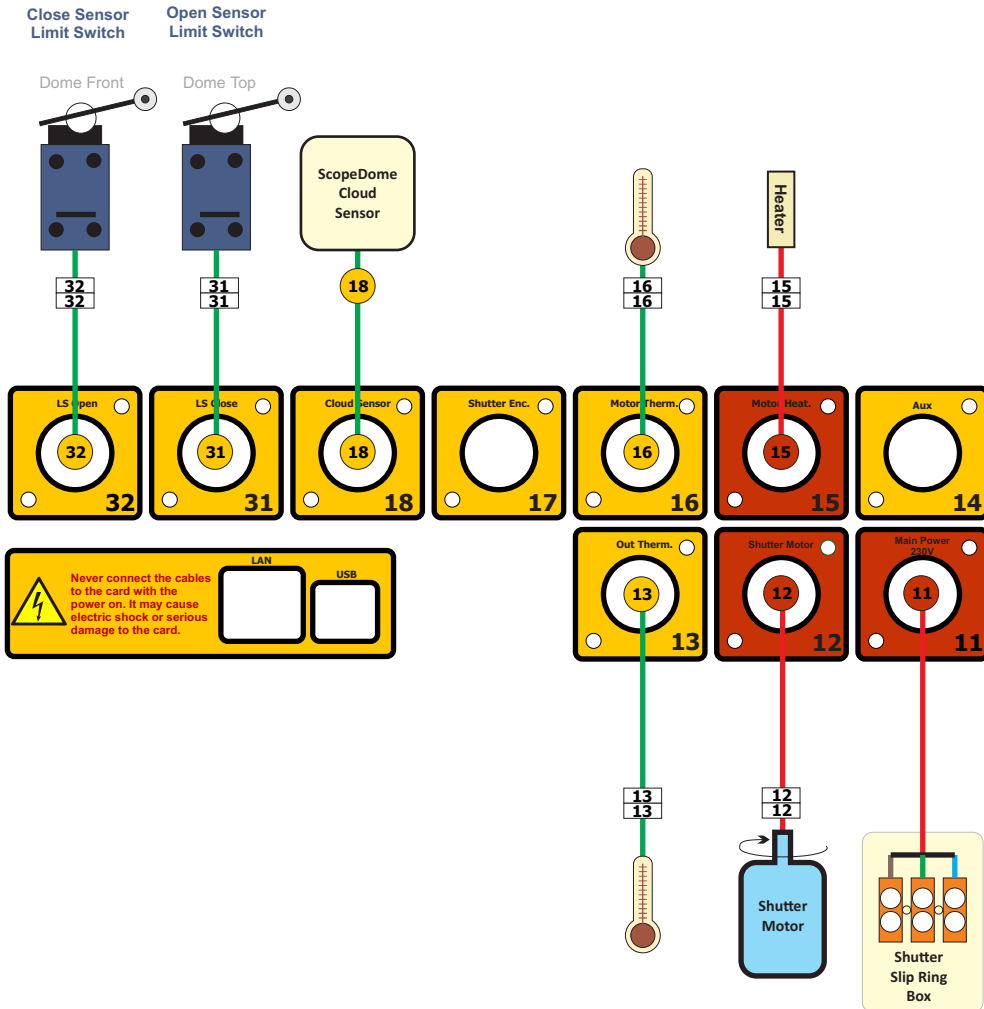

# 3M,4M,55M - PlugAndPlay wiring

## Shutter part



### Opis



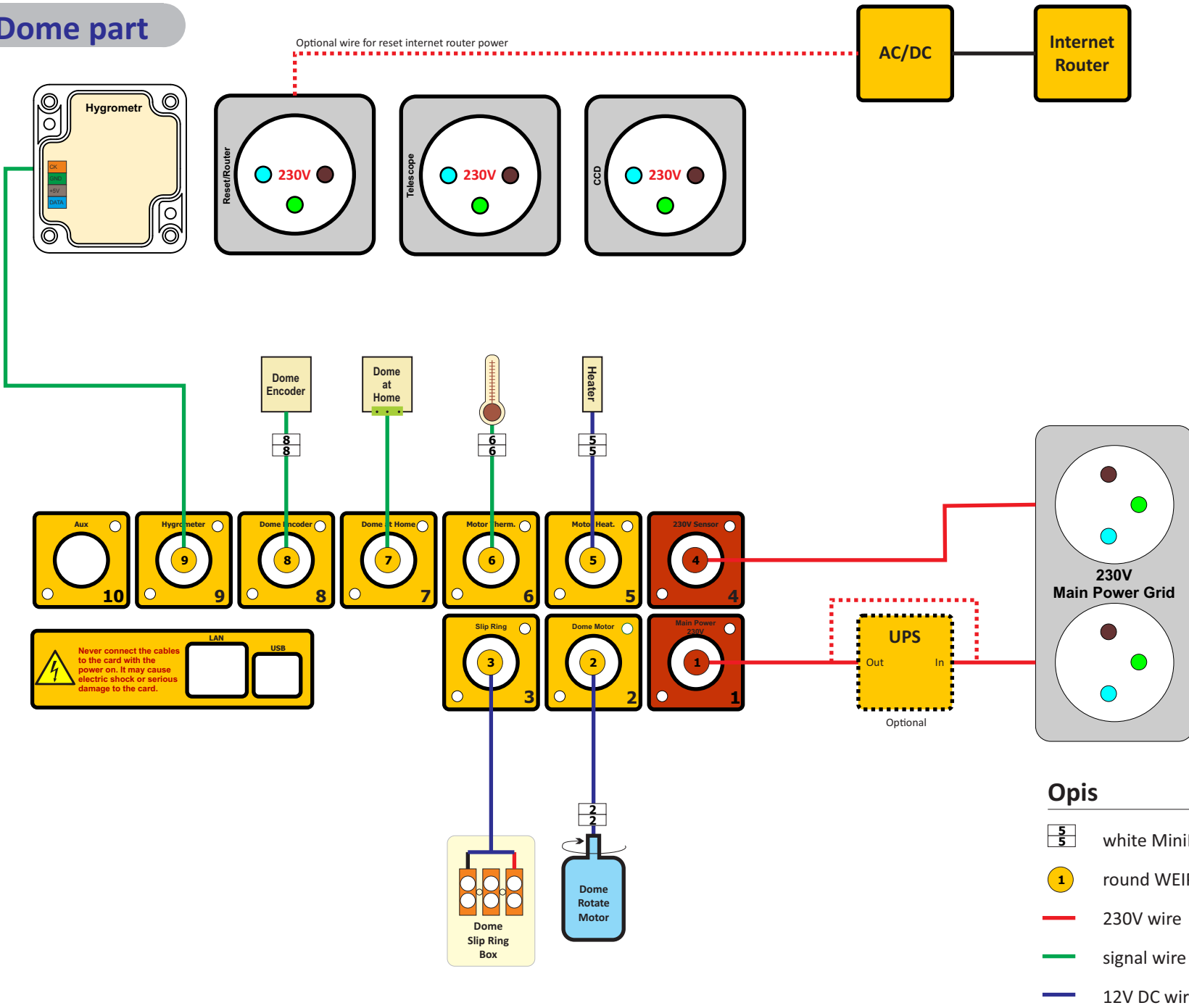

-  white MiniFit connector
-  round WEIP'u connector
-  230V wire
-  signal wire

# 2M - PlugAndPlay wiring

## Dome part



### Opis



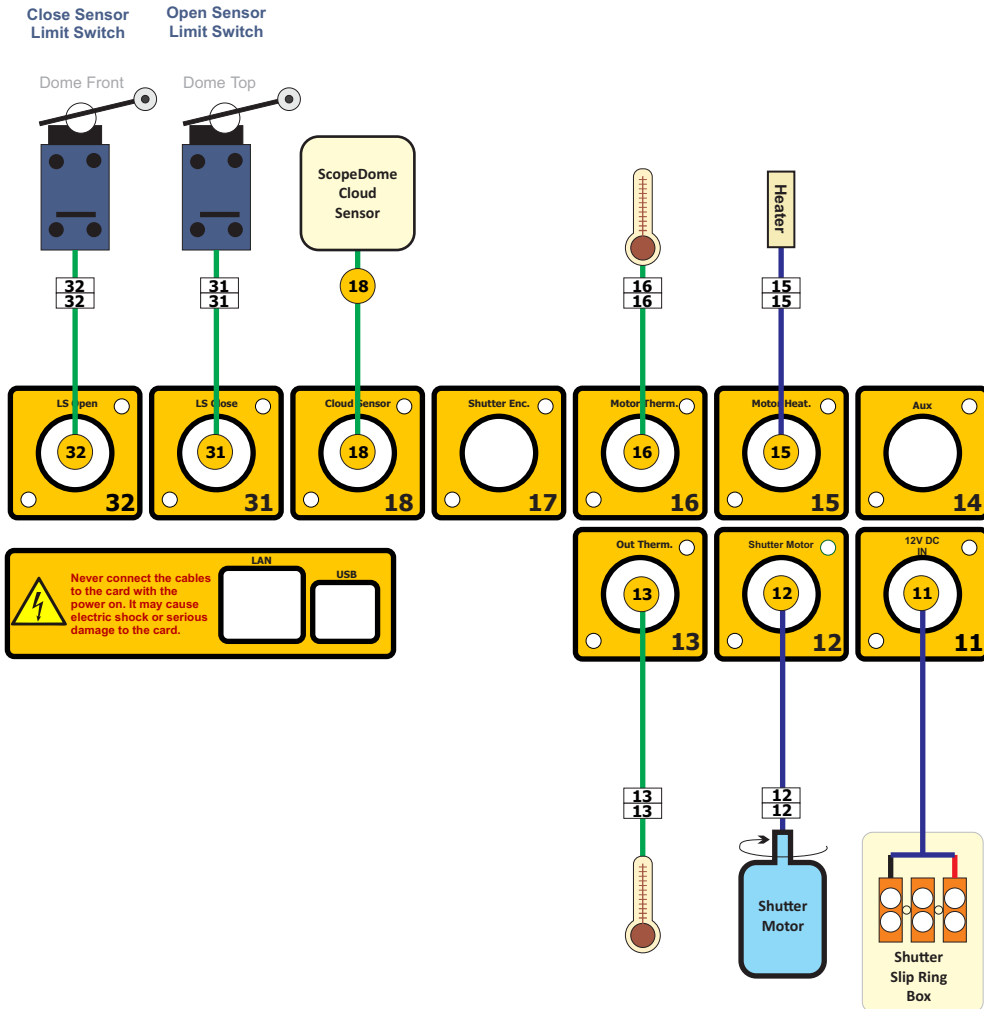

-  white MiniFit connector
-  round WEIP'u connector
-  230V wire
-  signal wire
-  12V DC wire

# 2M - PlugAndPlay wiring

## Shutter part





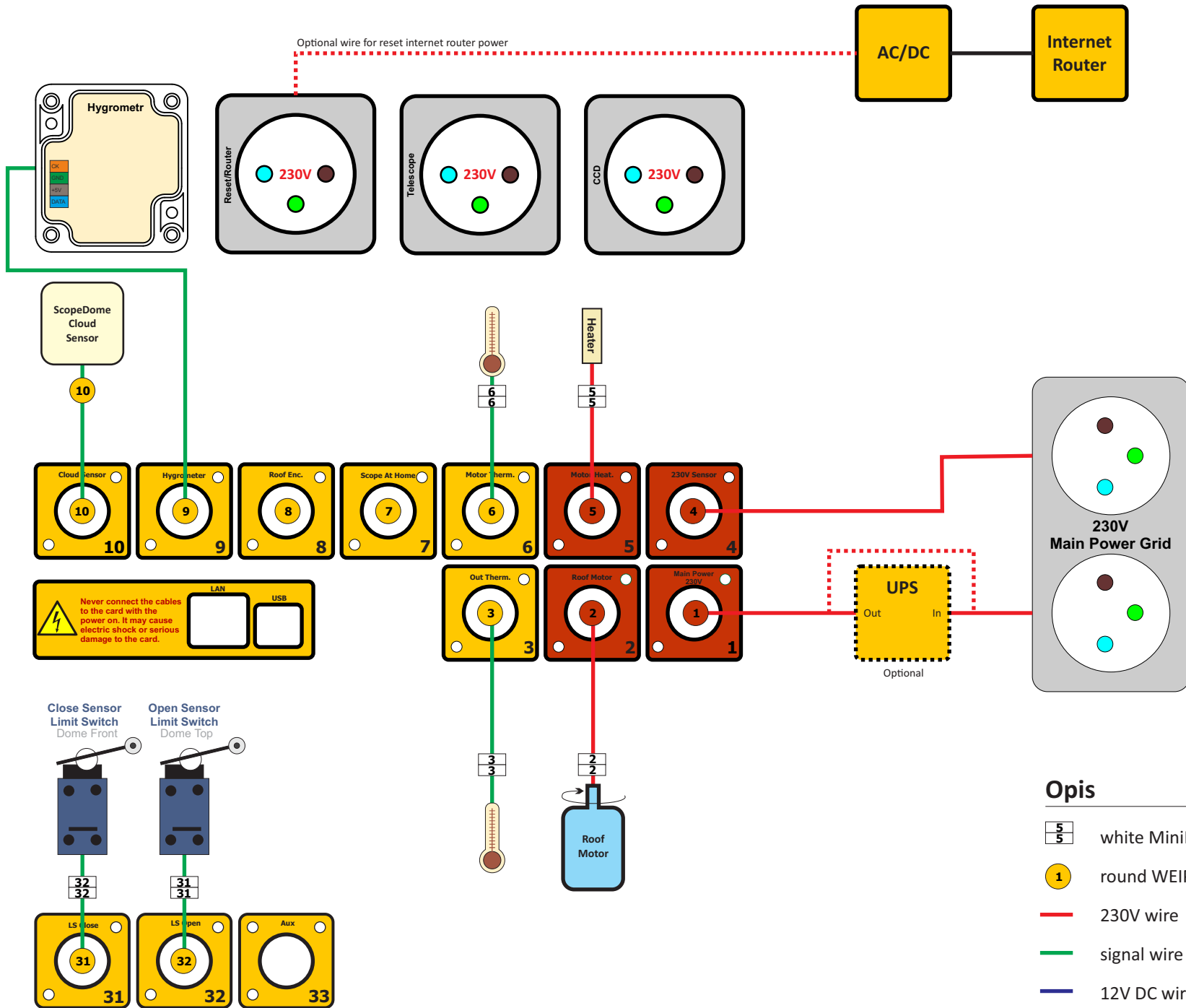

### Opis

-  white MiniFit connector
-  round WEIP'u connector
-  230V wire
-  signal wire
-  12V DC wire

# RollOff Roof - PlugAndPlay wiring



## Opis

-  white MiniFit connector
-  round WEIP'u connector
-  230V wire
-  signal wire
-  12V DC wire