



# SkyTracker™ Pro Camera Mount Instruction Manual

Product #3322

# Table of Content

Table of Content.....	2
1. SkyTracker™ Pro Camera Mount Overview.....	3
2. SkyTracker™ Pro Camera Mount Assembly.....	5
2.1. Introduction.....	5
2.2. Parts List.....	5
2.3. Assembly Terms.....	6
2.4. SkyTracker™ Pro Camera Mount Assembly.....	7
3. Maintenance and Servicing.....	13
3.1. Maintenance.....	13
3.2. Trouble Shooting.....	13
3.3. iOptron Customer Service.....	14
3.4. Product End of Life Disposal Instructions.....	14
3.5. Battery Replacement and Disposal Instructions.....	14
Appendix A. Technical Specifications.....	15
IOPTRON ONE YEAR TELESCOPE, MOUNT, AND CONTROLLER WARRANTY.....	16



## WARNING!

***NEVER USE A TELESCOPE TO LOOK AT THE SUN WITHOUT A PROPER FILTER!  
Looking at or near the Sun will cause instant and irreversible damage to your eye.  
Children should always have adult supervision while observing.***

***Please don't charge the battery or use USB power at or below 0°C (32°F), otherwise the rechargeable battery might be permanently damaged.***

Rev.1.0

iOptron Corp. reserves the rights to revise this instruction without notice. Actual color/contents/design may differ from those described in this instruction.

# 1. SkyTracker™ Pro Camera Mount Overview

Introducing The SkyTracker™ Pro -- iOptron's next generation camera tracking device! After 4 years leading the camera tracker market, SkyTracker™ has been the tool of choice for photographers worldwide, ushering in the astrophotography genre of outdoor photography. Now iOptron has been just pushing it to perfection.



Figure 1. SkyTracker™ Pro mount head

Upgraded from SkyTracker™, the Pro is more compact, small enough to fit on your palm, better precision, silent tracking, it even has a built-in rechargeable power source that runs for over 24 hours of continuous operation. The improved precision polar scope maintains a fine engraved reticule, now features adjustable illumination with eight brightness levels. Using with our smart phone app, quick and accurate polar alignment is just a joy.

The SkyTracker™ Pro features four tracking rates, 1X or sidereal, 1/2X for sky and landscape, solar and lunar. All 4 tracking rates work in both northern and southern hemispheres. We have also added a quick slew mode with both forward and reverse to help quickly reframing your image without disrupting the camera's position.

We have made big improvements on the SkyTracker™ Pro's removable alt-azimuth base, which features a precision bubble level, degree markings for the altitude and a built-in post for the azimuth control. You can also mount the SkyTracker™ Pro head (without the base) directly to any standard photographic tripod with 1/4" or 3/8" threads. The SkyTracker™ Pro is certainly a must-have tool for any photographer interested in astrophotography or wide field astrophotography.

**Features:**

- All metal structure with ABS covers
- Attaches to a camera tripod with 3/8" or 1/4" threads
- Accepts cameras weighing up to 3 kg (6.6 lbs)
- Silent tracking for smooth camera motion, perfect for long-term exposures
- Detachable alt-azi base with fine latitude and azimuth adjusters for easy polar alignment
- Reversible mounting post for both 3/8" and 1/4" threaded ball head mounting
- Includes iOptron AccuAlign™ dark-field illuminated polar scope
- Adjustable polar scope illumination with eight brightness levels
- 4 tracking speed (1X, 1/2X, solar and lunar). 1X celestial tracking for imaging the sky and stars; 1/2X tracking speed for imaging both the starry night and the landscapes at the same time
- Quick slew (180X max.) for camera framing adjustment
- Operation in both northern and southern Hemisphere
- Built-in rechargeable battery with Micro USB port for power and charging
- Over 24 hours of operation (20°C)
- 1/4" – 3/8" thread converter included
- Padded carry bag included
- Optional ball heads available separately (#3305A)
- Optional tripod (#3221)
- Optional counterweight balance kit (#3324)

## 2. SkyTracker™ Pro Camera Mount Assembly

### 2.1. Introduction

You have just purchased a tracking camera mount that is capable of taking you to a new level of astrophotography. When aligned the polar axis of the SkyTracker™ Pro camera mount with the celestial North Pole (CNP), or celestial South Pole (CSP), the mount will provide rotation matching the celestial sphere rotation around the Earth. Since all celestial objects appear to rotate around the CNP, or CSP, the polar axis allows the mount to rotate with the celestial sphere and provide accurate tracking for visual observations and astrophotography.

The AccuAlign™ polar scope, along with the Quick Polar Alignment procedure, will provide an easy and accurate polar alignment for the mount.

The following sections of this manual provide detailed steps required to successfully set up and operate the SkyTracker™ Pro mount.

### 2.2. Parts List

#### PARTS INCLUDED:

The SkyTracker™ Pro camera mount shipping box contains:

- SkyTracker™ Pro camera mount
- Alt-azi base (installed)
- AccuAlign™ dark field illuminated polar scope
- Micro USB charging cable
- Padded carry bag



Figure 2. Parts in a SkyTracker™ Pro package

#### PARTS NEEDED:

The following parts are needed to take astrophotography but are not included in the package:

- A sturdy tripod with 3/8" or 1/4" threaded post.

- An power source with a USB port for mount charging, such as a smartphone charger, a laptop with a USB port, or car cigarette adapter, or a portable battery pack
- A ball head adapter
- A camera

**YOU MAY NEED IT FOR POLAR ALIGNMENT:**

- iPhone/iPad app for accurate polar alignment  
(<https://itunes.apple.com/us/app/ioptron-polar-scope/id564078961?mt=8>)
- or Android phone polar finder app  
(<https://play.google.com/store/apps/details?id=com.techhead.polarfinder>)
- Or other application/program to calculate the pole star position. Please refer to FAQ session under Support at <http://www.ioptron.com> for more information.

**ONLINE CONTENTS (click under “Support” menu) www.iOptron.com**

- This manual
- Accessories
- Tips for set up
- Reviews and feedback from other customers

**2.3. Assembly Terms**

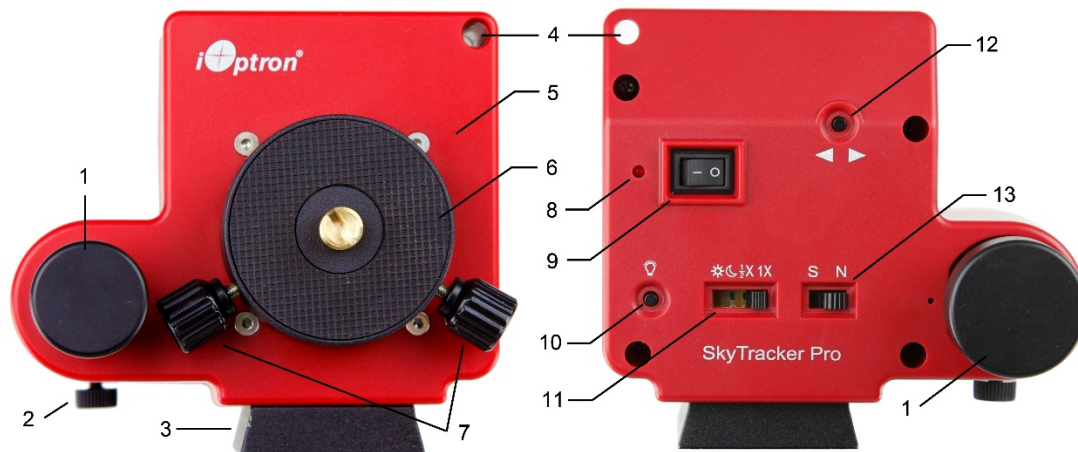

Figure 3. Front and back view of a SkyTracker™ Pro mount head

- |  |  |
|--|--|
| 1- Polar scope                         | 8- Battery status indicator                    |
| 2- Polar scope locking screw           | 9- Power switch                                |
| 3- Dovetail base                       | 10- Polar scope illumination adjustment button |
| 4- Polar sight hole                    | 11- Tracking speed switch                      |
| 5- Single axis equatorial mount body   | 12- RA fast slew button                        |
| 6- Camera mounting block               | 13- South/north switch                         |
| 7- Camera mounting block locking screw |  |

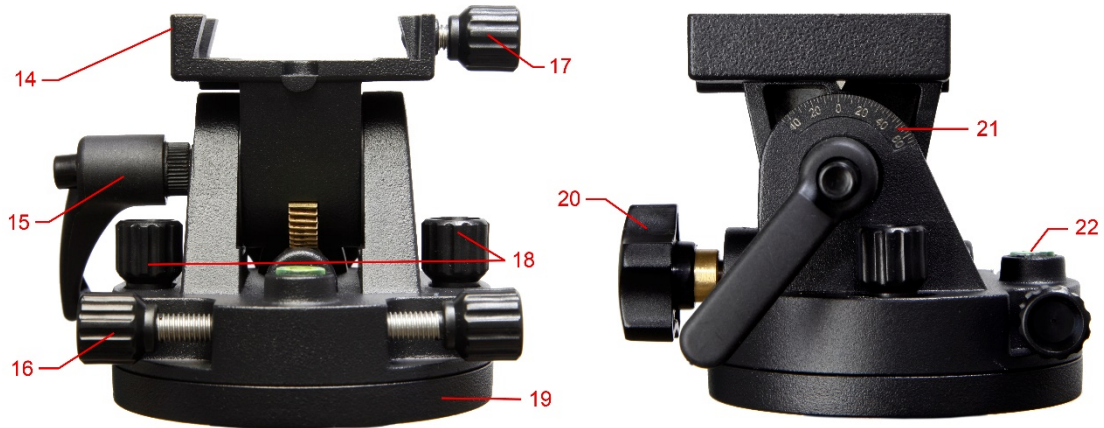

Figure 4. Alt-azi adjusting base

- 14- Dovetail saddle
- 15- Latitude lock
- 16- Azimuth adjusting knob
- 17- Dovetail locking knob
- 18- Azimuth locking knob

- 19- Base
- 20- Latitude adjustment knob
- 21- Latitude scale
- 22- Leveling bubble

## 2.4. SkyTracker™ Pro Camera Mount Assembly

**NOTE:** The SkyTracker™ Pro mount is a precision astronomical instrument. It is highly recommended that you read the entire manual and become familiar with the nomenclature and functions of all components before starting the assembly.

### STEP 1. Check/charge the battery

The SkyTracker™ Pro is shipped with battery partially charged. It is suggested to fully charge the battery before the first time use. Insert the micro USB plug into the USB port at the side of the mount (see Figure 5), and connect the other end of the USB cable into a USB port of a computer, a smart phone charger or a portable battery pack (not included). The input power should be 5V, 1A. It usually takes 5 hours to charge the internal Li-Poly battery to reach 80% of full power. When the battery is fully charged the battery status indicator should flash rapidly (about 5Hz). You may charge the SkyTracker™ Pro with the power switch either on or off. (However, when the power switch is turned off, the battery status indicator does not function). When the indicator stays steady on, the battery power should be sufficient for your session. When the indicator blinks slowly (about 0.5Hz), it indicates a low power and recharging is necessary.



Figure 5. Micro USB powering/charging port



Please don't charge the battery or use USB power when temperature is at or below 0°C (32°F), otherwise the rechargeable battery might be permanently damaged.

If the mount is not to be used for an extended period of time, charge the battery in full and recharge every 6 months.

## STEP 2. Install the polar scope

Before installing the polar scope onto the mount, face the polar scope to a bright source, such as the sky (**but not the SUN**) or a lamp from a distance. Adjust the eyepiece to focus the reticle pattern. Then face the polar scope to a distant object and look through the eyepiece. If you cannot see the distant object clearly, the polar scope is not focused for your eyesight. Release a few turns of the Lock ring (or hold the objective lens and turn it counterclockwise). Turn the Objective lens until the image is focused. Retighten the Lock ring.

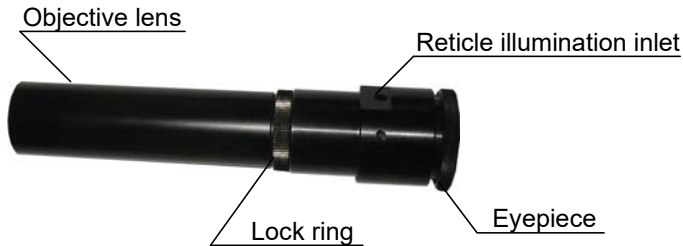

Figure 6. AccuAlign™ dark field illuminated polar scope



Figure 7. Insert the polar scope

Remove the front cover of the polar telescope. Loosen the Polar Scope Locking Screw until it does not intrude into the polar scope mounting hole. Gently insert the polar scope all the way into the polar scope mounting hole from the back of the mount and with the flat platoon on the polar scope facing left, as shown in Figure 7. Finger tighten (not too tight) the Polar Scope Locking Screw. Turn the mount power on. Press the Polar Scope Illumination Adjustment Button to adjust the brightness of the dark field reticle.

**Tip:** The polar scope can be tightened by the Polar Scope Locking Screw from either the side or bottom. The bottom position is better for storage.

## STEP 3. Attach the SkyTracker™ Pro to a tripod

The SkyTracker™ Pro can be mounted to a stable tripod with or without the alt-azi base, as shown in Figure 8. When the alt-azi base is not used, a ball head (#3305A, not included) is suggested for easy adjustment.





Figure 8. Mounting the SkyTracker™ Pro to a tripod

The dovetail base of the SkyTracker™ Pro comes with a 1/4"-3/8" thread converter, as shown in FIG 9, It fits directly to the 3305A ball head quick release plate or any other platform with 1/4" or 3/8" threads screw. The alt-azi base fits to any standard camera or astrophotography tripod with 1/4" or 3/8" threads by insert the 1/4"-3/8" thread converter into it, as needed.

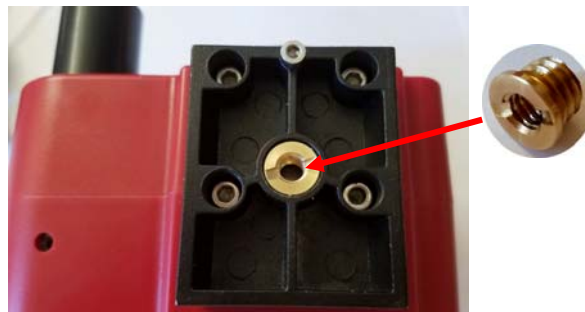

Figure 9. Mount head dovetail base with 1/4"-3/8" thread converter

#### STEP 4. Install a ball head and mounting a camera

A DSLR camera can be mounted to the SkyTracker™ Pro in many ways. Here are two most practical methods.

1. For a light payload (less than 1.2kg or 2.6lbs, including lens), a DSLR can be attached directly to the SkyTracker™ Pro mount through a ball head. Loosen the two camera mounting block locks to remove the Camera Mounting Block from the SkyTracker™ Pro. If your ball head has a 1/4" threaded hole, thread the brass Mounting Screw into the Mounting Block with 1/4" threaded side facing outside (Figure 10a). If the ball head mounting hole is 3/8" threaded, let 3/8" threaded side facing outside (Figure 10b). Attach the Mounting Block to the base of a ball head (not included) and make sure they are secured, as shown in Figure 10c. Reattach the mounting block to the SkyTracker™ Pro and tighten the two locking screws. Finally, attach the quick release plate of the ball head to the bottom of the DSLR camera and secure it with the 1/4" screw, then attached the camera to the ball head (Figure 11).



(a)



(b)



(c)



Figure 11. Attach a camera

Figure 10. Attach a ball head to the mounting block

2. For a heavy payload (more than 1.2kg or 2.6lbs, including lens), a counterweight (CW) balance kit should be used (sold separately, #3324) as shown in **Error! Reference source not found.** Please retreat the polar scope by about 10 mm after the polar alignment is done, to avoid a possible interference between the CW balance kit and the polar scope.



Figure 12. Mounting a camera with CW balance kit

## STEP 5. Set the SkyTracker™ Pro mount

The SkyTracker™ Pro head can be attached to the Alt-azi base in two opposite directions depends on your latitude position. Choose the one with the center of gravity of the system as close to the center of the base as possible.

Assuming you are in northern hemisphere, facing the SkyTracker™ Pro to approximately the north. You may use a compass or an electronic compass from your smart phone. Please note that true north may not be aligned to the magnetic north from you compass. However, most smart phone compass may adjust it for you. Release the Latitude Lock a half turn by simply rotate the locking lever counterclockwise. Set the latitude scale at your current latitude by turning the Latitude Adjustment Knob and retighten the latitude lock. The latitude lock handle can be rotated to any suitable position by pulling and turning. Loosen the two Azimuth Locking Knobs, adjust the Azimuth Adjusting Knobs to align the polar axis to the north, then tighten the Azimuth Locking Knobs. More details on polar alignment are in next step.

When powering on, the SkyTracker™ Pro will be in tracking mode with a rate depends on the selection of the tracking speed switch position: If your goal is only take the wide field image of the sky and stars, set the tracking speed to 1X (celestial tracking speed). With a good polar alignment, this will keep the stars rounded in your image.. If you would like to take the image of both the starry sky and the night landscape at the same time, you need to set the tracking speed at 1/2X. This will let you take clear images of both the sky and the land objects at a proper exposure. Solar speed is for tracking the Sun and lunar speed for the moon.

Set the south/north switch to N when in the northern hemisphere and to S when in the southern hemisphere.

You may fast slew the RA axis at 180X speed by pressing and holding the RA Fast Slew Button ◀▶. Release and press ◀▶ again the RA will slew in reverse direction.

## STEP 6. Polar Alignment

To achieve accurate tracking, precise polar alignment is crucial. SkyTracker™ Pro offers 3 polar alignment methods.

### 1. *Easy alignment through polar sight hole*

Aiming through the polar sight hole to the Polaris (or Sigma Octantis) while adjusting the azimuth and altitude angles until the Polaris appears in the center of the field of view. Locking all the knobs when done. (This method is less accurate, but useful if the polar scope missing).

### 2. *Easy alignment through polar scope*

Do exactly the same as above, but look through the polar scope. When putting the Polaris at the cross hairs of the polar scope, the misalignment to north pole is about 40 min (or about 1 degree in southern hemisphere with Sigma Octantis).

### 3. *Quick Polar Alignment*

Using iOptron's AccuAlign™ dark field illuminated polar scope as shown in Figure 6 for easy and accurate polar alignment. This is achieved by making the polar axis of the mount parallel to the Earth's axis of rotation.

Press the power switch on the mount to turn the SkyTracker™ Pro on. Look through the polar scope eyepiece. Adjust the eyepiece to bring the reticle dial in focus. As indicated in

Figure 13, the Polar Scope Dial has been divided into 12 hours along the angular direction with 10 min tics. There are 2 groups, 6 concentric circles marked from 36' to 44' and 60' to 70', respectively. The 36' to 44' concentric circles are for polar alignment in the northern

hemisphere using Polaris. While the 60' to 70' circles are for polar alignment in the southern hemisphere using Sigma Octantis. The 12 o'clock mark should be on top.

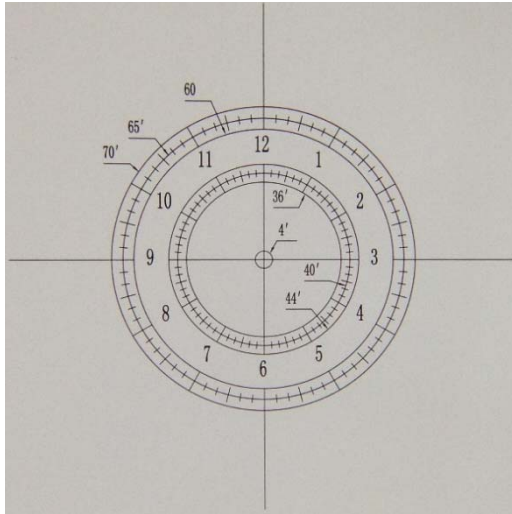

Figure 13. Polar scope dial



Figure 14. Polar scope app on an iPhone

To maximize the benefits of the iOptron polar scope for polar alignment, you need to know where the Polaris is in the northern (Sigma Octantis in southern) hemisphere. You may find this information via an iPhone/iPad app (iOptron Polar Scope in Apple iTunes store). Shown in Figure 14 is a screen shot of an iPhone chart. For example, on August 10, 2016, 17:50:18 in Boston, USA (Lat N42°30'28" and Long W71°08'49"), the Polaris Position is 00hr 18.4m and Radius is 40.2min (the green dot on the chart).

Adjust the mount in latitude (using Latitude Adjustment Knob) and azimuth (Azimuth Adjusting Knobs) directions to place Polaris in the same position on the Polar Scope Dial as indicated on your iPhone/iPad screen. In this case, the Polaris will be located at a radius of 40.2' and an angle of 00 hour 18.4 minute. Android phone users may refer to Android polar finder app (<https://play.google.com/store/apps/details?id=com.techhead.polarfinder>)

You may also use other program/software to calculate the pole star position.

**Enjoy using your SkyTracker™ Pro!**

## 3. Maintenance and Servicing

### 3.1. Maintenance

The SkyTracker™ Pro camera mount is designed to be maintenance free. Do not overload the mount. Do not drop the mount. This will damage the mount or degrade the tracking accuracy permanently. Use a damp cloth to clean the mount if necessary. Do not use solvent.

### 3.2. Trouble Shooting

#### 1. Unit does not power on?

Make sure battery is fully charged.

#### 2. Polar scope dial is not illuminated or is not bright enough?

Make sure that the polar scope is slide all the way in and the illumination LED is at the center of the dial opening. Press the illumination adjustment button to change LED intensity. Contact iOptron if a green LED is needed for those who can't identify the red color.

#### 3. The polar scope dial is not focused?

Please adjust the polar scope eyepiece to focus your eye sight on to the polar scope dial. See STEP 2 on page 8.

#### 4. Can't see star clearly through the polar scope while doing polar alignment?

Adjust objective lens by tuning the long tube while looking through the polar scope eyepiece. See STEP 2 on page 8.

#### 5. The star is trailing while imaging?

Polar alignment is critical to the tracking accuracy. Make sure your polar alignment is correct. The tracking speed is set at 1X for sky imaging. Correct Northern/Southern hemisphere is selected.

#### 6. Where should I put the Polaris when doing polar alignment?

You may have one of following choices:

- iPhone App for iOptron polar scope available here:  
<https://itunes.apple.com/us/app/ioptron-polar-scope/id564078961?mt=8>
- Android app for iOptron polar alignment here:  
<https://play.google.com/store/apps/details?id=com.techhead.polarfinder>
- Or you can download and install a window based program:  
<http://www.polarfinder.com/windows.html>
- Or a Mac/windows based program:  
<http://www.trutek-uk.com/takahashi/polarisfinder1-2en.htm>. When mapping the Polaris position from the 24 hrs dial to iOptron polar scope, you need to divide it by 2, *i.e.* the reading on the dial is 10 o'clock, then you should put the Polaris in your polar scope at 5 o'clock.
- Or download and print the following table/chart to bring with you to the field if you don't what to carry any electronics, as stated:  
<http://www.covingtoninnovations.com/michael/blog/1302/index.html>
- The last approach is just putting the Polaris at the center. It may be good enough for a short exposure depends on the lens you are using.

#### 7. My mount still does not work properly after tried the above solution?

Contact iOptron at support@ioptron.com for technical support.

### **3.3. iOptron Customer Service**

If you have any question concerning your mount, contact iOptron Customer Service Department. Customer Service hours are 9:00 AM to 5:00 PM, Eastern Time, Monday through Friday. In the unlikely event that the mount requires factory servicing or repairing, write or call iOptron Customer Service Department first to receive a RMA# before returning the mount to the factory. Please provide details as to the nature of the problem as well as your name, address, e-mail address, purchase info and daytime telephone number. We have found that most problems can be resolved by e-mails or telephone calls. So please contact iOptron first to avoid returning the mount for repair.

It is recommended to send technical questions to [support@ioptron.com](mailto:support@ioptron.com) or call in the U.S. 1.781.569.0200.

### **3.4. Product End of Life Disposal Instructions**



This electronic product is subject to disposal and recycling regulations that vary by country and region. It is your responsibility to recycle your electronic equipment per your local environmental laws and regulations to ensure that it will be recycled in a manner that protects human health and the environment. To find out where you can drop off your waste equipment for recycling, please contact your local waste recycle/disposal service or the product representative.

### **3.5. Battery Replacement and Disposal Instructions**



The internal rechargeable battery should be long life if used properly. Nevertheless if a battery needs to be replaced within 90 days from purchase, contact iOptron for free replacement. Otherwise new battery is available at [www.ioptron.com](http://www.ioptron.com).

Battery Disposal- Batteries contain chemicals that, if released, may affect the environment and human health. Batteries should be collected separately for recycling, and recycled at a local hazardous material disposal location adhering to your country and local government regulations. To find out where you can drop off your waste battery for recycling, please contact your local waste disposal service or the product representative.

## Appendix A. Technical Specifications

Mount	Ultra compact single axis EQ
Payload (MAX)	6.6 lbs (3kg)
Mount weight	685 gm with battery
Mount weight with base	1150 gm (2.53 lbs) with battery
Body material	Die-cast aluminum with ABS cover
RA shaft	Φ25mm, steel
Worm wheel	Φ74mm, 144 teeth aluminum alloy
Worm gear	Φ11mm, brass
Worm period	600 sec
Bearing	4 pieces
Motor drive	DC servo
Tracking	R.A. automatic
Tracking speed	1X Cel, 1/2 Cel, solar, lunar, N/S
Fast slew speed	180X, forward and reverse
Polar sight hole	~ 8° FOV
Polar scope	6° FOV, dark field illuminated (8 adjustable intensity)
Power requirement	Internal rechargeable battery
Battery type	Li-Poly, 3.7V, 2000mAh
Duration of operation	Over 24 hours at 20°C
Power charge port	Micro USB (5V), 80% charge in 5 hours
Body dimension	115x115x95 mm
Operation Temperature	-15~40°C
Mounting ring	Ø53 mm, 3/8" or 1/4" post threads
Body-base connection	Vixen dovetail, 3/8" socket (1/4" converter)
Alt-Azi adjustable Base	Vixen style saddle, 3/8" socket
Latitude adjustment range	-30° ~ 65° (with Alt-azi base)
AZ adjustment range	±5°
Base diameter	Φ80 mm
Warranty	One year limited (90 day on battery)

## IOPTRON ONE YEAR TELESCOPE, MOUNT, AND CONTROLLER WARRANTY

A. iOptron warrants your telescope, mount, or controller to be free from defects in materials and workmanship for one year. iOptron will repair or replace such product or part which, upon inspection by iOptron, is found to be defective in materials or workmanship. As a condition to the obligation of iOptron to repair or replace such product, the product must be returned to iOptron together with proof-of-purchase satisfactory to iOptron.

B. The Proper Return Merchant Authorization Number must be obtained from iOptron in advance of return. Call iOptron at 1.781.569.0200 to receive the RMA number to be displayed on the outside of your shipping container.

All returns must be accompanied by a written statement stating the name, address, and daytime telephone number of the owner, together with a brief description of any claimed defects. Parts or product for which replacement is made shall become the property of iOptron.

The customer shall be responsible for all costs of transportation and insurance, both to and from the factory of iOptron, and shall be required to prepay such costs.

iOptron shall use reasonable efforts to repair or replace any telescope, mount, or controller covered by this warranty within thirty days of receipt. In the event repair or replacement shall require more than thirty days, iOptron shall notify the customer accordingly. iOptron reserves the right to replace any product which has been discontinued from its product line with a new product of comparable value and function.

This warranty shall be void and of no force of effect in the event a covered product has been modified in design or function, or subjected to abuse, misuse, mishandling or unauthorized repair. Further, product malfunction or deterioration due to normal wear is not covered by this warranty.

IOPTRON DISCLAIMS ANY WARRANTIES, EXPRESS OR IMPLIED, WHETHER OF MERCHANTABILITY OF FITNESS FOR A PARTICULAR USE, EXCEPT AS EXPRESSLY SET FORTH HERE. THE SOLE OBLIGATION OF IOPTRON UNDER THIS LIMITED WARRANTY SHALL BE TO REPAIR OR REPLACE THE COVERED PRODUCT, IN ACCORDANCE WITH THE TERMS SET FORTH HERE. IOPTRON EXPRESSLY DISCLAIMS ANY LOST PROFITS, GENERAL, SPECIAL, INDIRECT OR CONSEQUENTIAL DAMAGES WHICH MAY RESULT FROM BREACH OF ANY WARRANTY, OR ARISING OUT OF THE USE OR INABILITY TO USE ANY IOPTRON PRODUCT. ANY WARRANTIES WHICH ARE IMPLIED AND WHICH CANNOT BE DISCLAIMED SHALL BE LIMITED IN DURATION TO A TERM OF ONE YEAR FROM THE DATE OF ORIGINAL RETAIL PURCHASE.

Some states do not allow the exclusion or limitation of incidental or consequential damages or limitation on how long an implied warranty lasts, so the above limitations and exclusions may not apply to you.

This warranty gives you specific legal rights, and you may also have other rights which vary from state to state.

iOptron reserves the right to modify or discontinue, without prior notice to you, any model or style telescope.

If warranty problems arise, or if you need assistance in using your telescope, mount, or controller contact:

iOptron Corporation  
Customer Service Department  
6E Gill Street  
Woburn, MA 01801  
[www.ioptron.com](http://www.ioptron.com)  
support@ioptron.com  
Tel. (781)569-0200  
Fax. (781)935-2860  
Monday-Friday 9AM-5PM EST

NOTE: This warranty is valid to U.S.A. and Canadian customers who have purchased this product from an authorized iOptron dealer in the U.S.A. or Canada or directly from iOptron. Warranty outside the U.S.A. and Canada is valid only to customers who purchased from an iOptron Distributor or Authorized iOptron Dealer in the specific country. Please contact them for any warranty.