

INSTRUCTION MANUAL

GSO—DOBSONIANS

200mm F/6 OTA

250mm F/5 OTA

300mm F/5 OTA

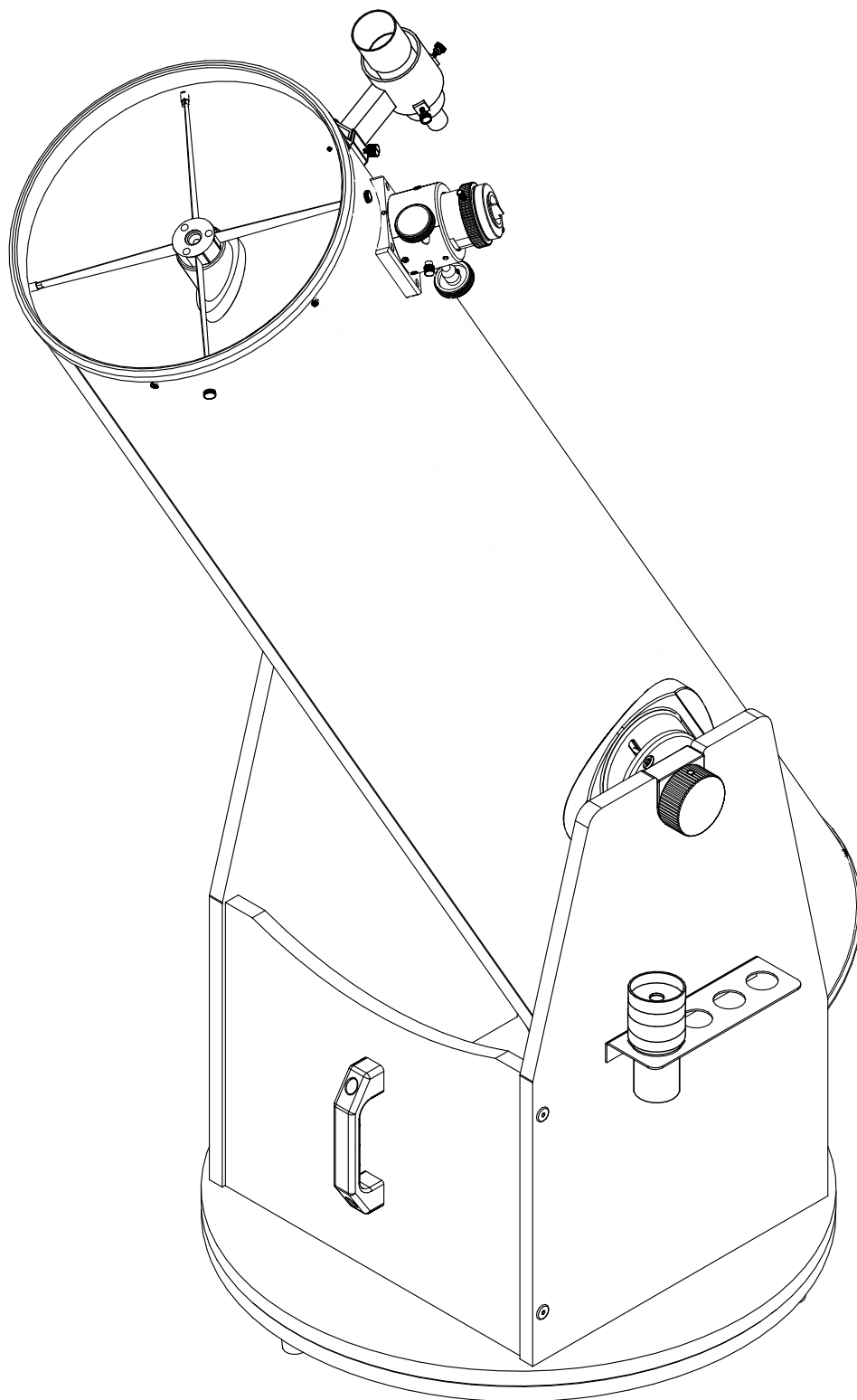

PART LIST

1. Wood Base

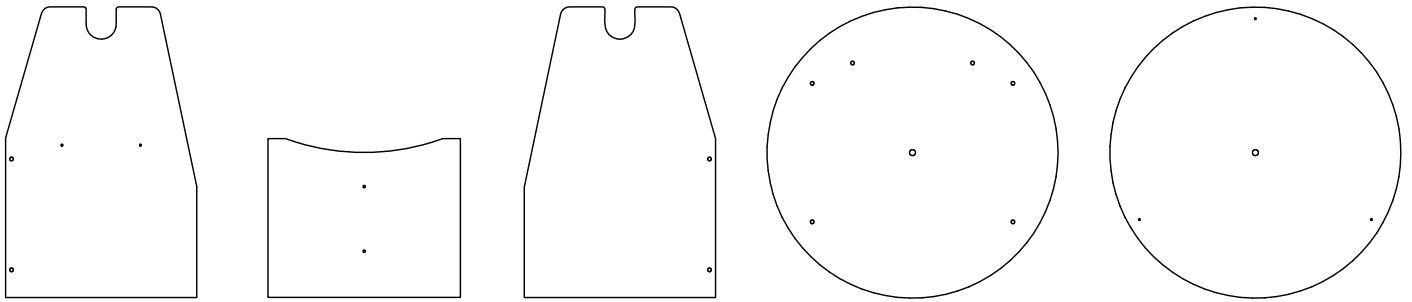

2. Screw parts list

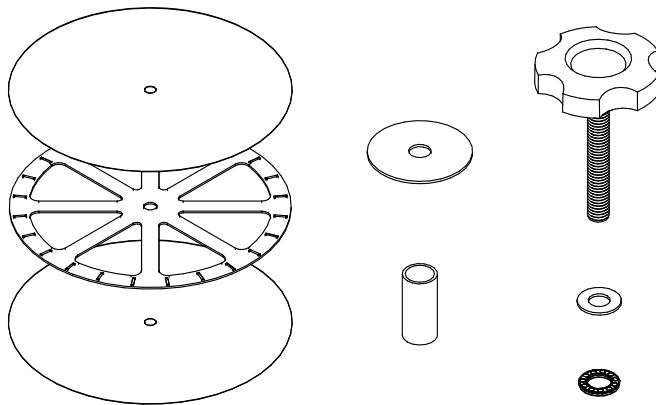

- Roller bearing plates x2
- Plastic roller bearing x1
- 5/16-18 adjustment bolt x1
- 8mm/16mm washer x1
- Roller bearing 8.5mm x 15mm x1
- Center bearing bushing x1
- 8.2mm/38mm washer x1

Self-tapping wood screw x10

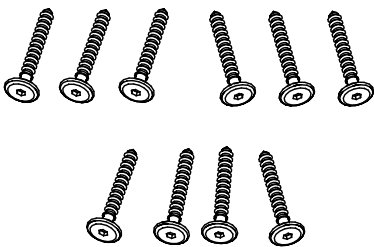

Eyepieces holder x1, Self-tapping wood screw x2

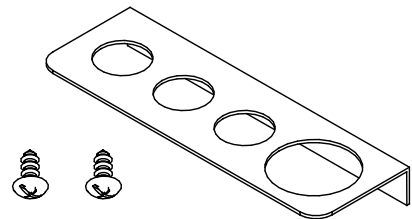

Plastic handle x1, 1/4-20 1-1/4" Screw x2

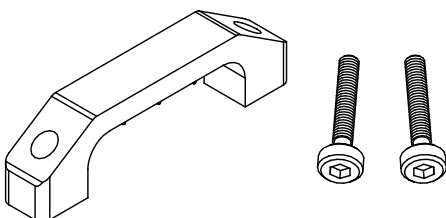

Plastic Feet x3, Self-tapping wood screw x3

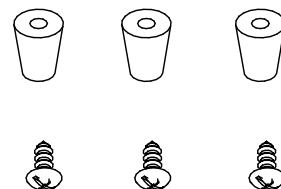

WOOD BASE ASSEMBLY

8",10" & 12" Dobsonian

A=Side Panels

B=Front Brace

C=Side Panels

D=Top Base plate

E=Ground Base plate

F=8.2mm/38mm Washer

G=Center bearing bushing

H=Self-tapping wood screw

I=5/16-18 adjustment bolt

J=8mm/16mm Washer

K=Roller bearing 8.5mm x 15mm

L=1/4-20 1-1/4" Screw

M=Plastic Handle

N=Plastic Feet

O=3/16 Self-tapping wood screw

P=1.25" & 2" Eyepieces holder

Q=3/16 Self-tapping wood screw

R=Roller bearing plates

S=Plastic roller bearing

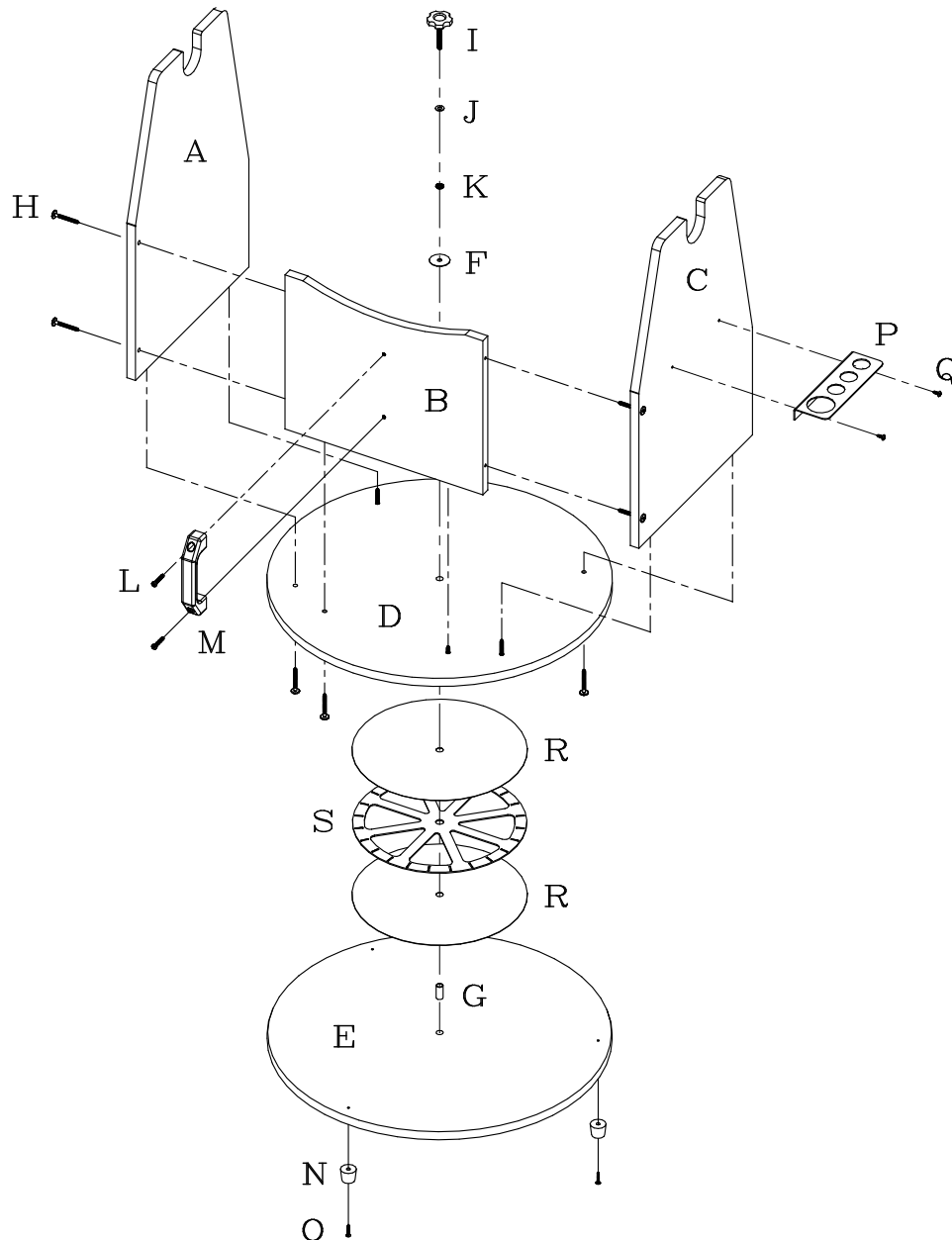

OPTICAL TUBE ASSEMBLY

Place the optical tube on the wood base.

Complete assembly of OTA and base.

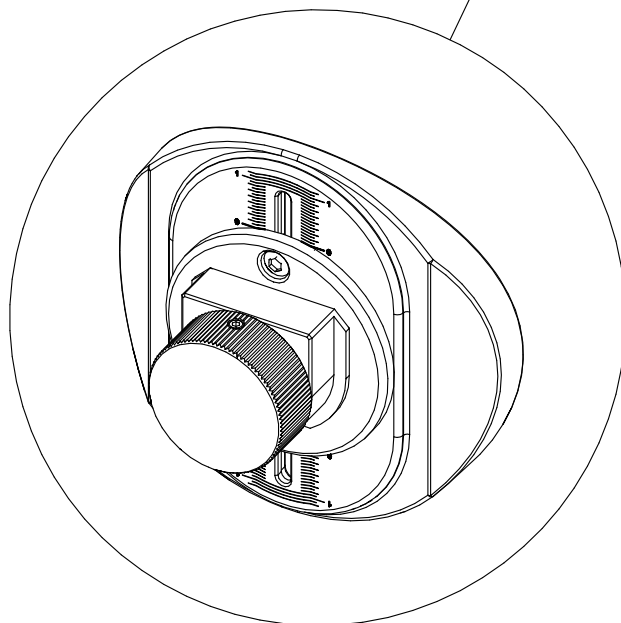
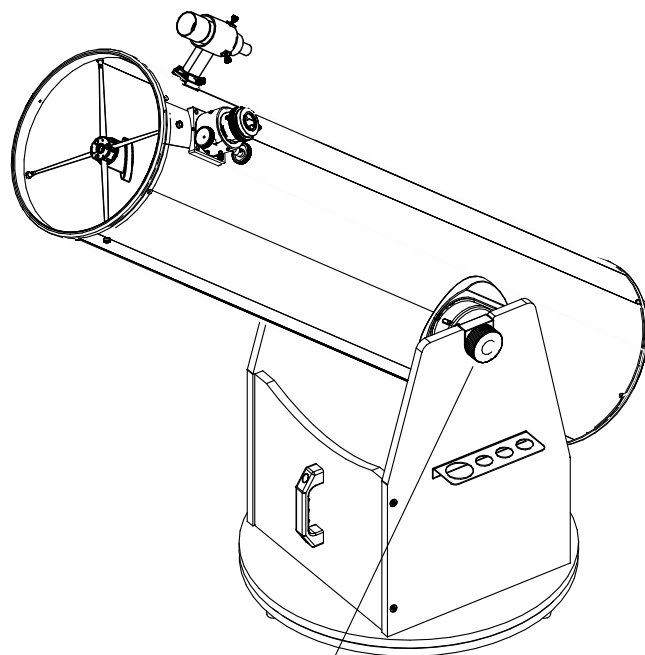
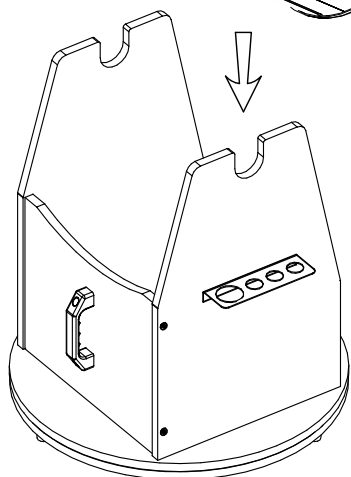
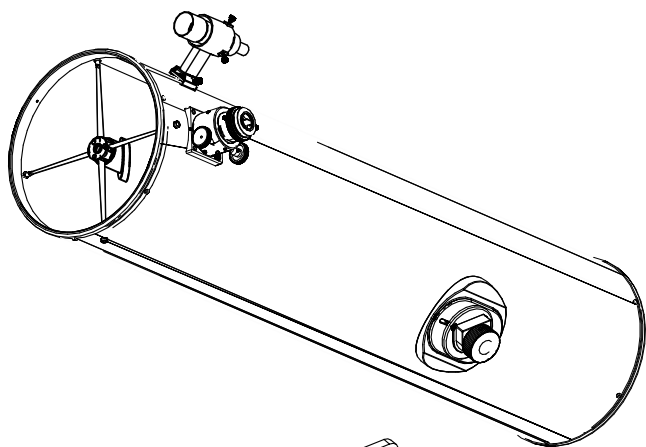

OPTICAL TUBE ASSEMBLY

1. Optical Tube Assembly

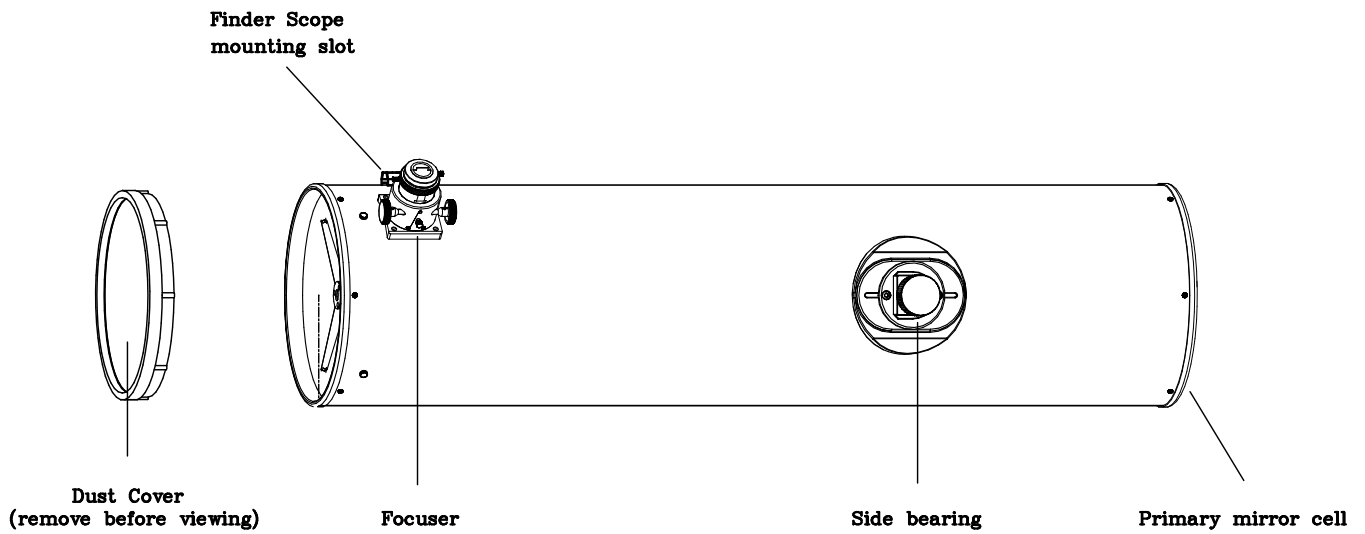

Locate the finder scope bracket and remove the rubber-o-ring on it. Position the o-ring into groove on the finderscope tube.

Slide the finder scope bracket into the mounting slot and tighten the screw to hold the bracket in place.

Loosen the two plastic adjusting screws on the bracket. Position the finder scope into the bracket by sliding it backwards until the rubber o-ring seats.

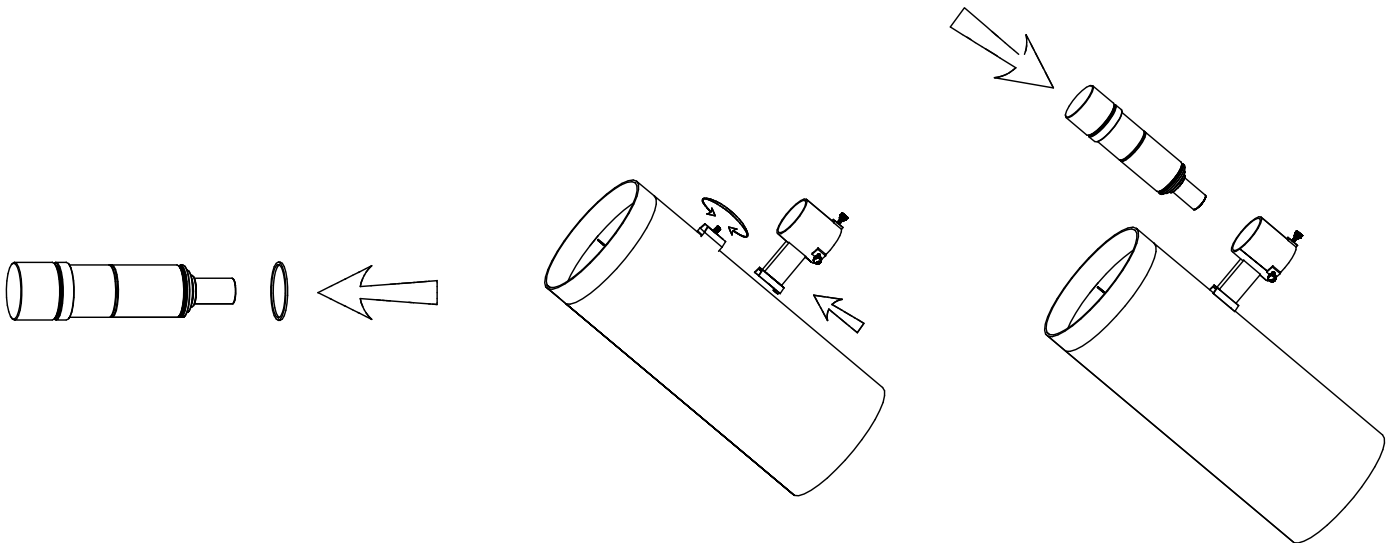

Remove the dust cover and Loosen the thumbscrews on the end of the focuser adapter.

Insert the 1.25" or 2" eyepiece and lightly tighten the thumbscrews to hold the eyepiece in place.

